



Llywodraeth Cymru  
Welsh Government

The Building Regulations 2010

# Approved Document

# A

- A1 Loading**
- A2 Ground movement**
- A3 Disproportionate collapse**

Structure

For use in Wales\*

2004 edition incorporating  
2010 amendments

## Main Changes in the 2004 Edition

This edition of Approved Document A, Structure, replaces the 1992 Edition (with 1994 and 2000 amendments edition). The main changes are:

### Use of Guidance

- a. **Eurocodes:** an announcement is given regarding the forthcoming introduction of the Structural Eurocodes and their National Annexes.
- b. **House construction:** reference is made to the intended publication of guidance by industry of alternative forms of house construction to that of traditional masonry.

### A1 and A2

#### Traditional dwellings

- c. The guidance on the sizing of timber floors and roofs for traditional house construction has been removed as the Timber Tables are now published by TRADA. However, the TRADA Tables are referenced under Section 2B.
- d. A revised map of basic wind speeds in accordance with BS6399:Part 2 replaces the superseded map which was based on BS CP3 Chapter V.
- e. Stainless steel cavity wall ties have been specified to all houses regardless of their location.
- f. The guidance on masonry walls to dwellings has been extended to enable the rules to be applicable when using either the appropriate British Standards or the emerging BS EN CEN Standards.
- g. The guidance on concrete foundations to houses has been revised to align with the recommendations given in the British Standards and other authoritative guidance. Recommendations on minimum foundation depths have also been included to counter the impact of predicted climate changes.
- h. The guidance on the design and construction of domestic garages has been extensively updated to reflect modern practice.

### A3

- i. Disproportionate collapse: the Application Limit to the Requirement (ie. the 5 storey limit) has been removed so as to bring all buildings under control of the A3 Requirement.

The modified guidance has been developed from commissioned research and consideration of the recommendations given in the forthcoming Eurocode N1991-1-7 on Accidental Actions.

This printing incorporates corrections to text and diagrams made since 2003.

## Main changes made by the 2010 amendments

This 2004 edition incorporating the 2010 amendments reflects the changes made as a result of the Building Regulations 2010 and Building (Approved Inspectors etc) Regulations 2010. The changes mainly reflect regulation number changes as a result of re-ordering. There have been no amendments to the substantive requirements in Schedule 1 (i.e. Parts A to P) of the Building Regulations.

Please note the simplification of the definition of 'room for residential purposes' in regulation 2 of the Building Regulations 2010. Please also note that L1(c) has now become regulation 40.

# Contents

|  |           |
|--|-----------|
| <b>Use of guidance</b>   | <b>7</b>  |
| The approved documents   | 7         |
| Limitation on requirements   | 7         |
| Materials and workmanship  | 7         |
| The workplace (health, safety and welfare) regulations 1992  | 7         |
| Other forms of house construction  | 8         |
| Eurocodes  | 8         |
| <b>Loading and ground movement:<br/>The Requirements A1/2</b>  | <b>9</b>  |
| <b>Guidance</b>  | <b>10</b> |
| Introduction   | 10        |
| <b>Section 1: Codes, standards and references for all building types</b>   | <b>11</b> |
| Introduction   | 11        |
| References   | 11        |
| Loading:   | 11        |
| Structural work of timber:   | 11        |
| Structural work of masonry:  | 11        |
| Structural work of reinforced, pre-stressed or plain concrete:   | 12        |
| Structural work of steel:  | 12        |
| Structural work of aluminium:  | 12        |
| Foundations:   | 12        |
| Ground movement (Requirement A2b)  | 12        |
| Existing buildings   | 13        |
| <b>Section 2: Sizes of structural elements for certain residential buildings and other small buildings of traditional construction</b> | <b>14</b> |
| General  | 14        |
| Definitions  | 14        |
| <b>Section 2A: Basic requirements for stability</b>  | <b>16</b> |
| <b>Section 2B: Sizes of certain timber members in floors and roofs for dwellings. Areas at risk from house longhorn beetle</b>         | <b>17</b> |
| Sizing of members  | 17        |
| House longhorn beetle  | 17        |
| <b>Section 2C: Thickness of walls in certain small buildings</b>   | <b>18</b> |
| Application  | 18        |
| Wall types   | 18        |

|   |           |
|---|-----------|
| The use of this section   | 18        |
| Conditions relating to the building of which the wall forms part  | 19        |
| Thickness of walls  | 20        |
| Conditions relating to the wall   | 24        |
| Construction materials and workmanship  | 25        |
| Loading on walls  | 31        |
| End restraint   | 32        |
| Openings, recesses, overhangs and chases  | 34        |
| Lateral support by roofs and floors   | 35        |
| Interruption of lateral support   | 38        |
| Small single-storey non-residential buildings and annexes   | 39        |
| <b>Section 2D: Proportions for masonry chimneys above the roof surface</b>  | <b>43</b> |
| Height to width relationship  | 43        |
| <b>Section 2E: Foundations of plain concrete</b>  | <b>44</b> |
| Conditions relating to the ground   | 44        |
| Design provisions   | 44        |
| Minimum width of strip foundations  | 44        |
| Minimum depth of strip foundations  | 46        |
| <b>Section 3: Wall cladding</b>   | <b>47</b> |
| General   | 47        |
| Technical approach  | 47        |
| Loading   | 47        |
| Fixings   | 48        |
| Further guidance  | 48        |
| <b>Section 4: Roof covering</b>   | <b>50</b> |
| Materials   | 50        |
| Re-covering of roofs  | 50        |
| <b>Disproportionate collapse:<br/>The Requirement A3</b>  | <b>51</b> |
| <b>Guidance</b>   | <b>52</b> |
| Performance   | 52        |
| Introduction  | 52        |
| <b>Section 5: Reducing the sensitivity of the building to disproportionate collapse<br/>in the event of an accident</b> | <b>53</b> |
| Alternative approach  | 55        |
| <b>Standards referred to</b>  | <b>56</b> |

## Diagrams

|  |    |
|--|----|
| <b>Diagram 1</b> Size and proportion of residential buildings of not more than three storeys | 19 |
| <b>Diagram 2</b> Size and proportion of non-residential buildings and annexes                | 21 |
| <b>Diagram 3</b> Determination of wall thickness   | 22 |
| <b>Diagram 4</b> Parapet walls: height   | 23 |
| <b>Diagram 5</b> Maximum floor area enclosed by structural walls                             | 24 |
| <b>Diagram 6</b> Map showing wind speeds in m/s for maximum height of buildings              | 26 |
| <b>Diagram 7</b> Maximum height of buildings   | 27 |
| <b>Diagram 8</b> Measuring storey and wall heights   | 28 |
| <b>Diagram 9</b> Declared compressive strength of masonry units                              | 30 |
| <b>Diagram 10</b> Maximum span of floors   | 32 |
| <b>Diagram 11</b> Differences in ground levels   | 33 |
| <b>Diagram 12</b> Openings in a buttressing wall   | 34 |
| <b>Diagram 13</b> Buttressing  | 35 |
| <b>Diagram 14</b> Sizes of openings and recesses   | 36 |
| <b>Diagram 15</b> Lateral support by floors  | 38 |
| <b>Diagram 16</b> Lateral support at roof level  | 39 |
| <b>Diagram 17</b> Size and location of openings  | 40 |
| <b>Diagram 18</b> Wall thickness   | 41 |
| <b>Diagram 19</b> Lateral restraint at roof level  | 42 |
| <b>Diagram 20</b> Proportions for masonry chimneys   | 43 |
| <b>Diagram 21</b> Elevation of stepped foundation  | 45 |
| <b>Diagram 22</b> Piers and chimneys   | 45 |
| <b>Diagram 23</b> Foundation dimensions  | 45 |
| <b>Diagram 24</b> Area at risk of collapse in the event of an accident                       | 55 |

## Tables

|  |    |
|--|----|
| <b>Table 1</b> Areas at risk from house longhorn beetle  | 17 |
| <b>Table 2</b> Wall types considered in this section   | 18 |
| <b>Table 3</b> Minimum thickness of certain external walls, compartment walls and separating walls   | 22 |
| <b>Table 4</b> Imposed loads   | 25 |
| <b>Table 5</b> Cavity wall ties  | 29 |
| <b>Table 6</b> Declared compressive strength of masonry units complying with BS EN 771-1 to -5 (N/mm <sup>2</sup> )  | 29 |
| <b>Table 7</b> Normalised compressive strength of masonry units of clay and calcium silicacet blocks complying with BS EN 771-1 and 2 (N/mm <sup>2</sup> ) | 31 |
| <b>Table 8</b> Value of Factor 'X'   | 37 |
| <b>Table 9</b> Lateral support for walls   | 37 |
| <b>Table 10</b> Minimum width of strip footings  | 46 |
| <b>Table 11</b> Building classes   | 53 |

# Use of guidance

---

## The approved documents

This document is one of a series that has been approved by the First Secretary of State for the purpose of providing practical guidance with respect to the requirements of Schedule 1 to and Regulation 7 of the Building Regulations 2010 (SI 2010/2214) for England and Wales.

**At the back of this document is a list of all the documents that have been approved and issued by the Secretary of State for this purpose.**

Approved Documents are intended to provide guidance for some of the more common building situations. However, there may well be alternative ways of achieving compliance with the requirements. **Thus there is no obligation to adopt any particular solution contained in an Approved Document if you prefer to meet the relevant requirement in some other way.**

## Other requirements

The guidance contained in an Approved Document relates only to the particular requirements of the Regulations which that document addresses. The building work will also have to comply with the requirements of any other relevant paragraphs in Schedule 1 to the Regulations. There are Approved Documents which give guidance on each of the parts of Schedule 1 and on Regulation 7.

## Limitation on requirements

In accordance with regulation 8, the requirements in Parts A to K and N of Schedule 1 to the Building Regulations do not require anything to be done except for the purpose of securing reasonable standards of health and safety for persons in or about the buildings.

## Materials and workmanship

Any building work which is subject to the requirements imposed by Schedule 1 to the Building Regulations shall be carried out in accordance with regulation 7. Guidance on meeting these requirements on materials and workmanship is contained in Approved Document 7.

Building Regulations are made for specific purposes, primarily the health and safety, welfare and convenience of people and for energy conservation. Standards and other technical specifications may provide relevant guidance to the extent that they relate to these considerations. However, they may also address other aspects of performance or matters which, although they relate to health and safety etc., are not covered by the Building Regulations.

When an Approved Document makes reference to a named standard, the relevant version of the standard to which it refers is the one listed at the end of the publication. However, if this version has been revised or updated by the issuing standards body, the new version may be used as a source of guidance provided it continues to address the relevant requirements of the Regulations.

## The workplace (health, safety and welfare) regulations 1992

The Workplace (Health, Safety and Welfare) Regulations 1992 contain some requirements which affect building design. The main requirements are now covered by the Building Regulations, but for further information see: Workplace health, safety and welfare, The Workplace (Health, Safety and Welfare) Regulations 1992, Approved Code of Practice and Guidance; The Health and Safety Commission, L24; Published by HMSO 1992; ISBN 0 11886 333 9.

The Workplace (Health, Safety and Welfare) Regulations 1992 apply to the common parts of flats and similar buildings if people such as cleaners and caretakers are employed to work in these common parts. Where the requirements of the Building Regulations that are covered by this Part do not apply to dwellings, the provisions may still be required in the situations described above in order to satisfy the Workplace Regulations.

### **Other forms of house construction**

This Approved Document includes guidance on structural elements of residential buildings of traditional masonry construction. It is recognised, however, that there are other suitable forms of construction in use in the housing sector some of which (e.g. timber framed) have been in common use for a number of years and have demonstrated an adequate performance in compliance with the A1 requirement. Such alternative forms include prefabricated timber, light steel and precast concrete framed construction.

A number of guidance documents relating to these alternative forms are presently being developed by industry. The intention is to reference these in this Approved Document as soon as they become available and are approved by the Secretary of State.

### **Eurocodes**

The British Standards Institution will shortly be publishing a series of Structural Eurocodes, together with their National Annexes. These Eurocodes are CEN Standards comprising many Parts which, when used in conjunction with their National Annexes and when approved by the Secretary of State, are intended to be referenced in this Approved Document as practical guidance on meeting the Part A Requirements.



## Loading and ground movement: The Requirements A1/2

This Approved Document deals with the following Requirements which are contained in the Building Regulations 2010.

| Requirement  | Limits on application |
|--|-----------------------|
| <b>Loading</b>   |                       |
| <p><b>A1.</b> (1) The building shall be constructed so that the combined dead, imposed and wind loads are sustained and transmitted by it to the ground:</p> <ul style="list-style-type: none"> <li>(a) safely; and</li> <li>(b) without causing such deflection or deformation of any part of the building, or such movement of the ground, as will impair the stability of any part of another building.</li> </ul> <p>(2) In assessing whether a building complies with sub paragraph (1) regard shall be had to the imposed and wind loads to which it is likely to be subjected in the ordinary course of its use for the purpose for which it is intended.</p> |                       |
| <b>Ground movement</b>   |                       |
| <p><b>A2.</b> The building shall be constructed so that ground movement caused by:</p> <ul style="list-style-type: none"> <li>(a) swelling, shrinkage or freezing of the subsoil; or</li> <li>(b) land-slip or subsidence (other than subsidence arising from shrinkage, in so far as the risk can be reasonably foreseen), will not impair the stability of any part of the building.</li> </ul>  |                       |

# Guidance

## Introduction

- 0.1** In the Secretary of State's view the requirements of A1 and A2 will be met by following the recommendations given in the documents listed in Section 1 or by adopting the guidance in Sections 2-4:
- (a) **Section 1** is relevant to all building types and lists Codes, Standards and other references for structural design and construction but, where they do not give precise guidance, consideration should be given to paragraph 0.2.
  - (b) **Section 2** give sizes of structural elements for certain residential buildings and other small buildings of traditional construction.
  - (c) **Section 3** gives guidance on the support and fixing of wall cladding.
  - (d) **Section 4** gives guidance where roofs are to be re-covered as a material alteration as defined in the Regulations.
- 0.2** The safety of a structure depends on the successful combination of design and completed construction, particularly:
- (a) The design should be based on identification of the hazards to which the structure is likely to be subjected and assessment of the risks. The selection of relevant critical situations for design should be made reflecting the conditions that can reasonably be foreseen during future use.
  - (b) Loading. Dead load, imposed load and wind load should be in accordance with the current Codes of Practice referred to in Section 1 of this document.
  - (c) Properties of materials.
  - (d) Detailed design and assembly of the structure.
  - (e) Safety factors.
  - (f) Workmanship.

The numeric values of safety factors, whether expressed explicitly or implicitly in design equations, or design values, should be derived from considerations of the above aspects of design and construction as a whole. A change in any one of these aspects may disturb the safety of the structure.

Loads used in calculations should allow for possible dynamic, concentrated and peak load effects that may occur.

- 0.3** Grandstands and structures erected in places of public assembly may need to sustain the synchronous or rhythmic movement of numbers of people. It is important to ensure that the design of the structure takes these factors into account so as to avoid the structure being impaired or causing alarm to people using the structure.

*Interim guidance on the design of grandstands may be found in 'Dynamic performance requirements for permanent grandstands subject to crowd action, Interim Guidance on assessment and design' published by the Institution of Structural Engineers, November 2001.*

Supplementary advice on the dynamic testing of grandstands and seating decking has been published in an Advisory Note by the Institution of Structural Engineers, June 2002.

# Section 1: Codes, standards and references for all building types

---

## Introduction

- 1.1 This section is relevant to all building types and lists codes, standards and other references for structural design and construction.

## References

### 1.2

#### **Loading:**

- (a) Dead and imposed loads  
BS 6399-1:1996 Loading for buildings. Code of practice for dead and imposed loads.
- (b) Wind loads  
BS 6399-2:1997 Loading for buildings. Code of practice for wind loads BRE digest 436 Parts 1, 2 and 3 (Brief guidance for using BS 6399-2:1996).
- (c) Imposed roof loads  
BS 6399-3:1998 Loading for buildings. Code of practice for imposed roof loads.

### 1.3

#### **Structural work of timber:**

- BS 5268-2:2002 Structural use of timber. Code of practice for permissible stress design, materials and workmanship.
- BS 5268-3:1998 Structural use of timber. Code of practice for trussed rafter roofs.
- BS 8103-3:1996 Structural design of low-rise buildings. Code of practice for timber floors and roofs for housing.

### 1.4

#### **Structural work of masonry:**

- BS 5628-1:1992 Code of practice for use of masonry. Structural use of unreinforced masonry.
- BS 5628-2:2000 Code of practice for use of masonry. Structural use of reinforced and pre-stressed masonry.
- BS 5628-3:2001 Code of practice for use of masonry. Materials and components, design and workmanship.
- BS 8103-1:1995 Structural design of low-rise buildings. Code of practice for stability, site investigation, foundations and ground floor slabs for housing.
- BS 8103-2:1996 Structural design of low-rise buildings. Code of practice for masonry walls for housing.

## 1.5

### **Structural work of reinforced, pre-stressed or plain concrete:**

BS 8110-1:1997 Structural use of concrete. Code of practice for design and construction.

BS 8110-2:1985 Structural use of concrete. Code of practice for special circumstances.

BS 8110-3:1985 Structural use of concrete. Design charts for singly reinforced beams, doubly reinforced beams and rectangular columns.

BS 8103-4:1995 Structural design of low-rise buildings. Code of practice for suspended concrete floors for housing.

## 1.6

### **Structural work of steel:**

BS 5950-1:2000 Structural use of steelwork in building. Code of practice for design in simple and continuous construction: hot rolled and welded sections.

BS 5950-2:2001 Structural use of steelwork in building. Specification for materials, fabrication and erection, hot rolled sections.

BS 5950-3-1:1990 Structural use of steelwork in building. Design in composite construction. Code of practice for design of simple and continuous composite beams.

BS 5950-4:1994 Structural use of steelwork in building. Code of practice for design of composite slabs with profiled steel sheeting.

BS 5950-5:1998 Code of practice for design of cold formed thin gauge sections.

BRE Digest 437 Industrial platform floors: mezzanine and raised storage.

## 1.7

### **Structural work of aluminium:**

BS 8118-1:1991 Structural use of aluminium. Code of practice for design.

BS 8118-2:1991 Structural use of aluminium. Specification for materials, workmanship and protection.

## 1.8

### **Foundations:**

BS 8002:1994 Code of practice for earth retaining structures.

BS 8004:1986 Code of practice for foundations.

## **Ground movement (Requirement A2b)**

- 1.9 There may be known or recorded conditions of ground instability, such as that arising from landslides, disused mines or unstable strata which, if ignored, can have a devastating effect on the safety of a building and its environs. Such conditions should be taken into account in the design of the building and its foundations. Attention is drawn to DOE Planning Policy Guidance Note 14 Development on unstable land (obtainable from The Stationery Office), which sets out the broad planning and technical issues relating to development on unstable land.

The Department has also sponsored a series of reviews aimed at determining the scale and nature of problems arising from mining instability, natural underground cavities and adverse foundation conditions. Databases of both subsidence incidents and subsidence potential produced from these reviews are available from the following licence holders:

British Geological Survey, Sir Kingsley Dunham Centre, Keyworth, Nottingham NG12 5GG.

Landmark, 7 Abbey Court, Eagle Way, Exeter, Devon EX2 7HY.

Peter Brett Associates, 16 Westcote Road, Reading, Berkshire RG20 2DE.

Catalytic Data Ltd, The Spinney, 19 Woodlands Road, Bickley, Kent BRI 2AD.

The reports from these reviews, which include 1:250,000 scale maps showing the distribution of the physical constraints, are available from the following organisations:

Arup Geotechnics, 1991. Review of mining instability in Great Britain.

Obtainable from Arup Geotechnics, Bede House, All Saints, Newcastle-upon-Tyne NE1 2EB.

Applied Geology Ltd, 1994. Review of instability due to natural underground cavities in Great Britain.

Obtainable from Kennedy & Donkin Ltd, 14 Calthorpe Road, Edgbaston, Birmingham B15 1TH.

Wimpey Environmental Ltd, and National House Building Council, 1995. Foundation conditions in Great Britain, a guide for planners and developers. Obtainable from ESNR International Ltd, 16 Frogmore Road, Hemel Hempstead, Hertfordshire HP3 9RW.

## Existing buildings

**1.10** Compliance with Part A (Structure) is required in certain classes of change of use of a building, subject to the control of Regulations 5 and 6. Guidance relevant to structural appraisals related to 'change of use' is given in the following documents:

- (a) BRE Digest 366: Structural Appraisal of Existing Buildings for Change of Use.
- (b) The Institution of Structural Engineers Report Appraisal of Existing Structures, 1996.

**Note:** With reference to the item 'design checks' in the above mentioned Institution of Structural Engineers report the choice of various partial factors should be made to suit the individual circumstances of each case.

## Section 2: Sizes of structural elements for certain residential buildings and other small buildings of traditional construction

### General

2.1 This section is presented as follows:

#### **Section 2A**

Basic requirements for stability.

#### **Section 2B**

Sizes of certain timber members in floors and roofs for dwellings.

Areas at risk from house longhorn beetle.

#### **Section 2C**

Thickness of masonry walls in certain residential buildings of not more than three storeys, small single-storey non-residential buildings and annexes.

#### **Section 2D**

Proportions for masonry chimneys.

#### **Section 2E**

Foundations of plain concrete.

2.2 Section 2A gives general rules which must be observed in following Sections 2B and 2C. Sections 2B to 2E may be used independently of each other.

Throughout this section the diagrams are only illustrative and do not show all the details of construction.

### Definitions

2.3 The following meanings apply to terms throughout this section:

**Buttressing wall** A wall designed and constructed to afford lateral support to another wall perpendicular to it, support being provided from the base to the top of the wall.

**Cavity width** The horizontal distance between the two leaves of a cavity wall.

**Compartment wall** A wall constructed as a compartment wall to meet the requirements of regulation B3(2).

**Dead load** The load due to the weight of all walls, permanent partitions, floors, roofs and finishes including services, and all other permanent construction.

**Imposed load** The load assumed to be produced by the intended occupancy or use, including the weight of movable partitions, distributed, concentrated, impact, inertia and snow loads, but excluding wind loads.

**Pier** A member which forms an integral part of a wall, in the form of a thickened section at intervals along the wall, so as to afford lateral support to the wall to which it is bonded or securely tied.

**Separating wall** A wall or part of a wall which is common to adjoining buildings, and constructed to meet the requirements of regulation B3(2).

**Section 2:** Sizes of structural elements for certain residential buildings and other small buildings of traditional construction

**Spacing** The distance between the longitudinal centres of any two adjacent timber members of the same type, measured in the plane of floor, ceiling or roof structure.

**Span** The distance measured along the centre line of a member between the centres of any two adjacent bearings or supports.

**Supported wall** A wall to which lateral support is afforded by a combination of buttressing walls, piers or chimneys acting in conjunction with floor(s) or roof.

**Wind load** The load due to the effect of wind pressure or suction.

## Section 2A: Basic requirements for stability

- 2A1** This section must be used in conjunction with sections 2B and 2C and its principles relate to all forms of low-rise residential buildings.
- 2A2** Adequate provision shall be made to ensure that the building is stable under the likely imposed and wind loading conditions. This will commonly necessitate meeting the following requirements:
- (a) That the overall size and proportioning of the building are limited in accordance with the specific guidance for each form of construction.
  - (b) That a suitable layout of walls (both internal and external) forming a robust 3 dimensional box structure in plan is constructed with restriction on the maximum size of cells measured in accordance with the specific guidance for each form of construction.
  - (c) That the internal and external walls are adequately connected either by masonry bonding or by using mechanical connections.
  - (d) That the intermediate floors and roof are of such construction and interconnection with the walls that they provide local support to the walls and also act as horizontal diaphragms capable of transferring the wind forces to buttressing elements of the building.

**Note:** A traditional cut timber roof (i.e. using rafters, purlins and ceiling joists) generally has sufficient built in resistance to instability and wind forces (e.g. from hipped ends, tiling battens, rigid sarking or the like). However, the need for diagonal rafter bracing equivalent to that recommended in BS 5268-3:1998 or Annex H of BS 8103-3:1996 for trussed rafter roofs should be considered especially for single-hipped and non-hipped roofs of greater than 40° pitch to detached houses.



## Section 2B: Sizes of certain timber members in floors and roofs for dwellings. Areas at risk from house longhorn beetle

### Sizing of members

**2B1** Guidance on the sizing of certain members in floors and roofs is given in ‘Span tables for solid timber members in floors, ceilings and roofs (excluding trussed rafter roofs) for dwellings’, published by TRADA, available from Chiltern House, Stocking Lane, Hughenden Valley, High Wycombe, Bucks HP14 4ND.

Alternative guidance is available in BS 5268-2:2002 Code of practice for permissible stress design, materials and workmanship, BS 5268-3:1998, Code of practice for trussed rafter roofs and BS 8103-3:1996 Structural design of low-rise buildings, Code of Practice for timber floors and roofs for dwellings.

### House longhorn beetle

**2B2** In the geographical areas specified in Table 1, softwood timber for roof construction or fixed in the roof space, including ceiling joists within the void spaces of the roof, should be adequately treated to prevent infestation by the house longhorn beetle (*Hylotrupes bajulus* L.).

Guidance on suitable preservative treatments is given within the British Wood Preserving and Damp-Proofing Association’s Manual (2000 revision), available from 1 Gleneagles House, Vernongate, South Street, Derby DE1 1UP.

**Table 1** Areas at risk from house longhorn beetle

| Geographical area  |
|--|
| In the Borough of Bracknell Forest the parishes of Sandhurst and Crowthorne. |
| The Borough of Elmbridge   |
| In the District of Hart, the parishes of Hawley and Yateley                  |
| The District of Runnymede  |
| The Borough of Spelthorne  |
| The Borough of Surrey Heath  |
| In the Borough of Rushmoor, the area of the former district of Farnborough   |
| The Borough of Woking  |

## Section 2C: Thickness of walls in certain small buildings

### Application

**2C1** This section applies to the following building types:

- (a) residential buildings of not more than three storeys;
- (b) small single-storey non-residential buildings;
- (c) small buildings forming annexes to residential buildings (including garages and outbuildings).

### Wall types

**2C2** Only the types of wall given in Table 2, which must extend to the full storey height, and parapet walls are considered in this section.

### The use of this section

**2C3** When using this section it should be noted that:

- (a) this section must be used in conjunction with Section 2A;
- (b) if wall thickness is to be determined according to paragraphs **2C5** to **2C13**, all appropriate design conditions given in this section must be satisfied;
- (c) walls should comply with the relevant requirements of BS 5628: Part 3: 2001, except as regards the conditions given in paragraphs **2C4** and **2C14** to **2C38**;
- (d) in formulating the guidance of this section the worst combination of circumstances likely to arise was taken into account. If a requirement of this part is considered too onerous in a particular case it may be appropriate to consider a minor departure on the basis of judgement and experience, or to show adequacy by calculation in respect of the aspect of the wall which is subject to the departure rather than for the entire wall;
- (e) the guidance given is based upon the compressive strengths of bricks and blocks being not less than indicated in Tables 6 and 7.

BS 5628-1:1992 gives design strengths for walls where the suitability for use of masonry units of other compressive strengths is being considered.

**Table 2** Wall types considered in this section

|  |
|--|
| <b>Residential buildings of up to three storeys</b>              |
| External walls   |
| Internal load-bearing walls                                      |
| Compartment walls  |
| Separating walls   |
| <b>Small single-storey non-residential buildings and annexes</b> |
| External walls   |
| Internal load-bearing walls                                      |

## Conditions relating to the building of which the wall forms part

**2C4** This Section applies only to buildings having proportions within the following parameters (see Diagrams 1 and 2):

**(a) residential buildings of not more than three storeys:**

- (i) the maximum height of the building measured from the lowest finished ground level adjoining the building to the highest point of any wall or roof should not be greater than 15m, subject to the limits of paragraph **2C16**;
  - (ii) the height of the building  $H$  should not exceed twice the least width of the building  $W_1$ ;
  - (iii) the height of the wing  $H_2$  should not exceed twice the least width of the wing  $W_2$  where the projection  $P$  exceeds twice the width  $W_2$ ;
- (b) small single-storey non-residential buildings:** height  $H$  should not exceed 3m and  $W$  (being the greatest length or width of the building) should not exceed 9m (see Diagram 2), subject to the limits of paragraph **2C16**;
- (c) annexes:** height  $H$  as variously indicated in Diagram 2 should not exceed 3m, subject to the limits of paragraph **2C16**.

**Diagram 1 Size and proportion of residential buildings of not more than three storeys**

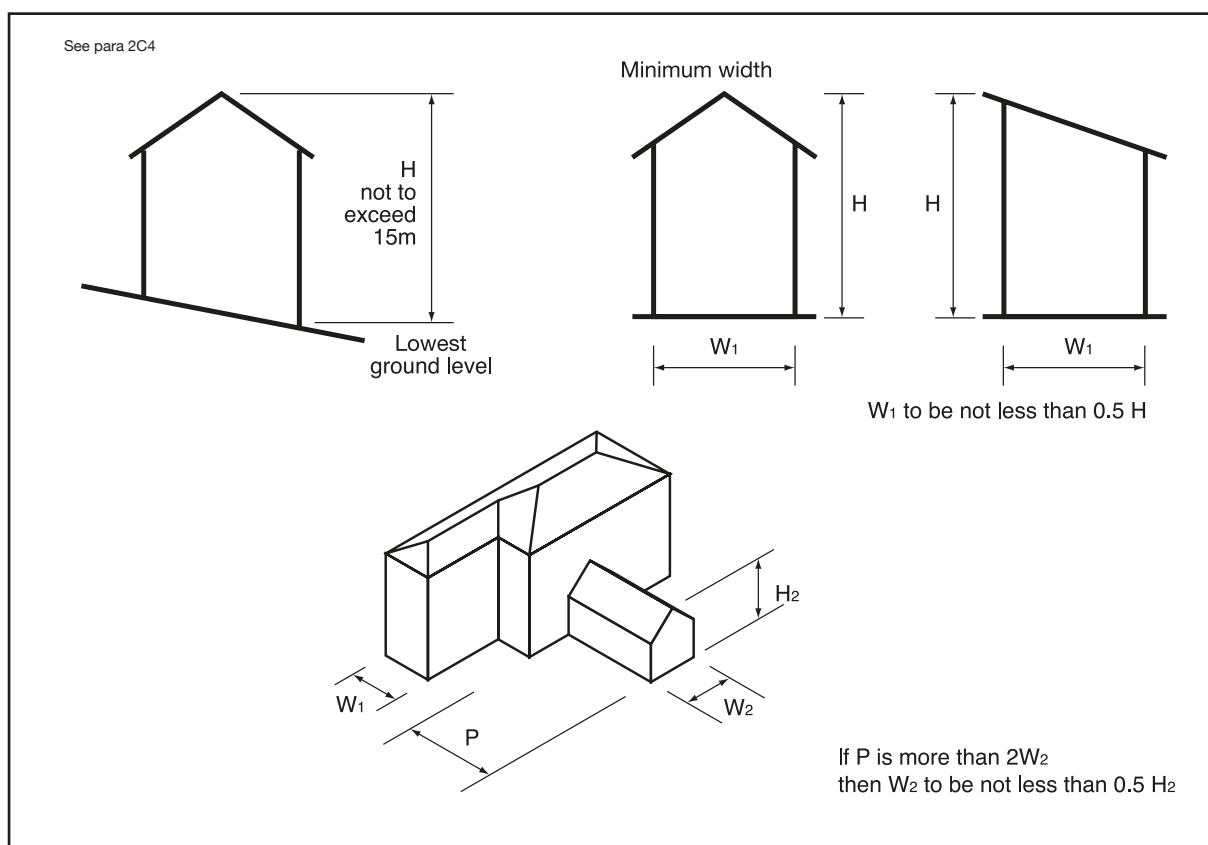

## Thickness of walls

- 2C5** General wall thickness may be determined according to this section provided:
- (a) conditions relating to the building of which the wall forms part (see paragraphs **2C4**, **2C14 to 2C16**, **2C38**); and
  - (b) conditions relating to the wall (see paragraphs **2C17 to 2C37**) are met. (See Diagram 3.)
- 2C6** **Solid external walls, compartment walls and separating walls in coursed brickwork or blockwork:** Solid walls constructed of coursed brickwork or blockwork should be at least as thick as 1/16 of the storey height. Further requirements are given in Table 3.
- 2C7** **Solid external walls, compartment walls and separating walls in uncoursed stone, flints, etc.:** The thickness of walls constructed in uncoursed stone, flints, clunches, bricks or other burnt or vitrified material should not be less than 1.33 times the thickness determined by paragraph **2C6**.
- 2C8** **Cavity walls in coursed brickwork or blockwork:** All cavity walls should have leaves at least 90mm thick and cavities at least 50mm wide. The wall ties should have a horizontal spacing of 900mm and a vertical spacing of 450mm, which is equivalent to 2.5 ties per square metre. Wall ties should also be provided, spaced not more than 300mm apart vertically, within a distance of 225mm from the vertical edges of all openings, movement joints and roof verges. For selection of wall ties for use in a range of cavity widths refer to Table 5. For specification of cavity wall ties refer to paragraph 2C19.
- For external walls, compartment walls and separating walls in cavity construction, the combined thickness of the two leaves plus 10mm should not be less than the thickness determined by paragraph 2C6 and Table 3 for a solid wall of the same height and length.
- 2C9** **Walls providing vertical support to other walls:** Irrespective of the material used in the construction, a wall should not be less in thickness than any part of the wall to which it gives vertical support.
- 2C10** **Internal load-bearing walls in brickwork or blockwork** (except compartment walls or separating walls): All internal load-bearing walls should have a thickness not less than:
- $$\frac{\text{(specified thickness from Table 3)}}{2} - 5\text{mm}$$
- except for a wall in the lowest storey of a three storey building, carrying load from both upper storeys, which should have a thickness as determined by the equation or 140mm whichever is the greatest.

Section 2C: Thickness of walls in certain small buildings

Diagram 2 Size and proportion of non-residential buildings and annexes

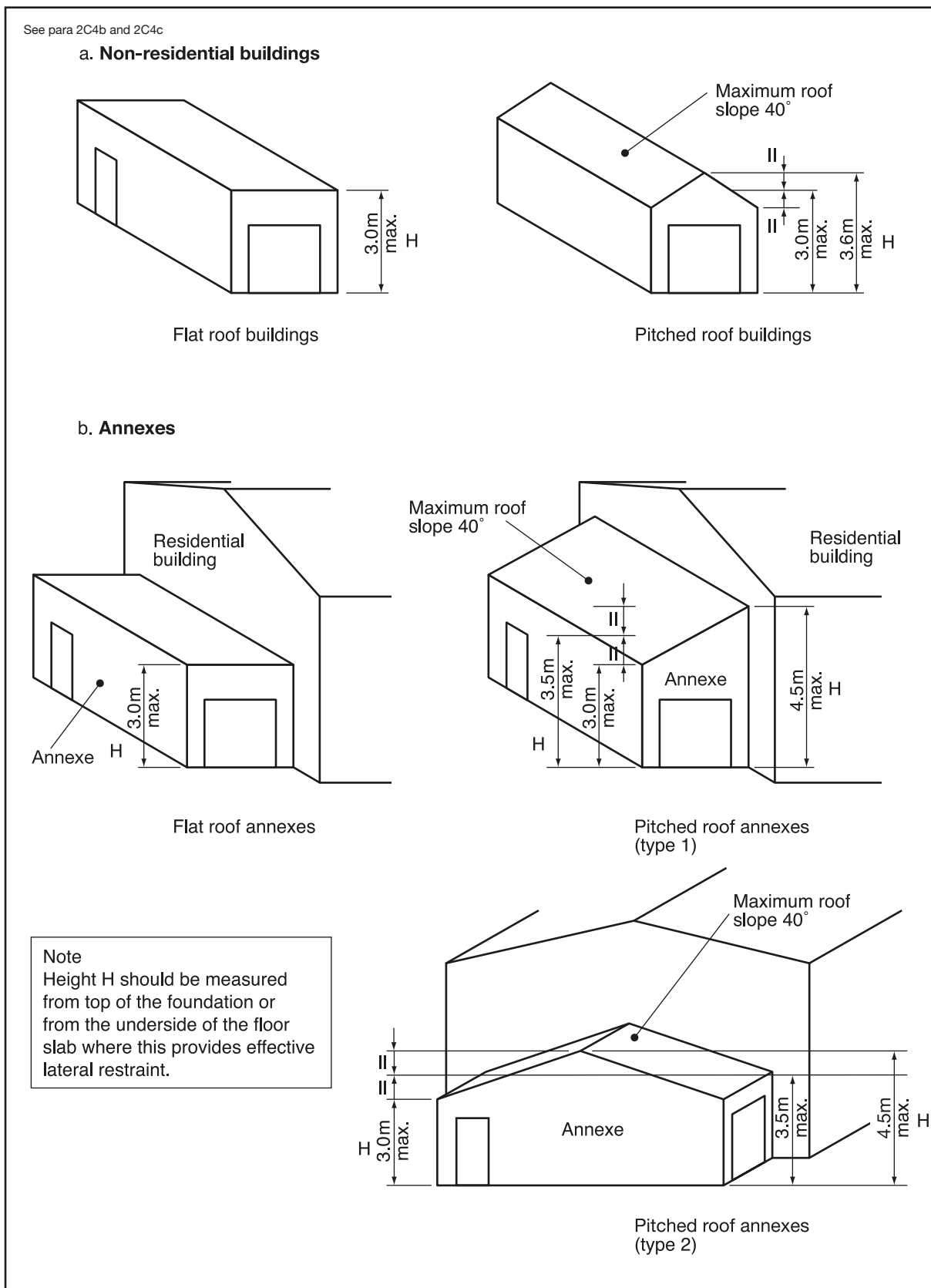

Section 2C: Thickness of walls in certain small buildings

Diagram 3 Determination of wall thickness

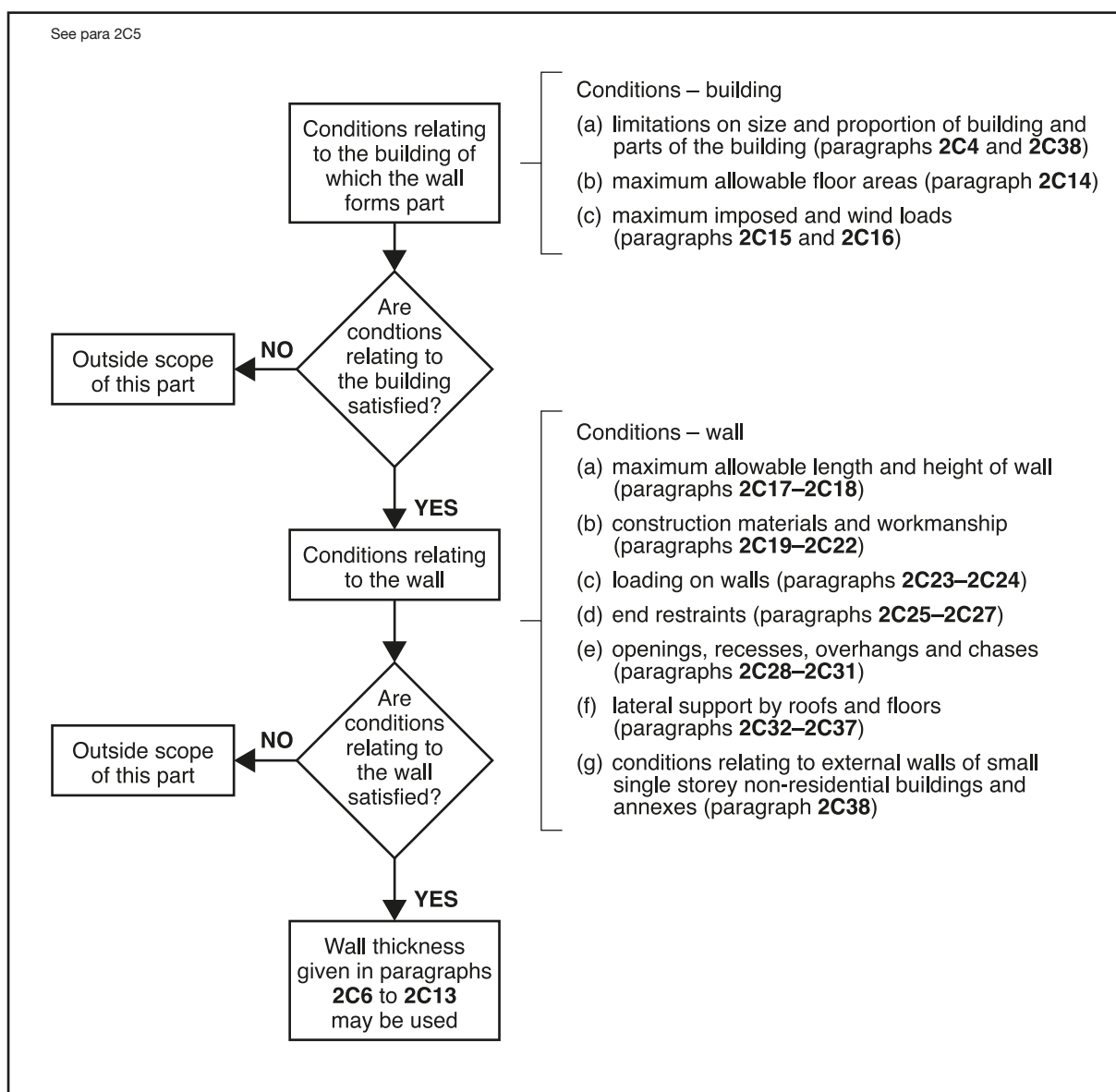

Table 3 Minimum thickness of certain external walls, compartment walls and separating walls

| Height of wall                      | Length of wall                     | Minimum thickness of wall  |
|-------------------------------------|------------------------------------|--|
| Not exceeding 3.5m                  | Not exceeding 12m                  | 190mm for whole of its height  |
| Exceeding 3.5m but not exceeding 9m | Not exceeding 9m                   | 190mm for whole of its height  |
|                                     | Exceeding 9m but not exceeding 12m | 290mm from the base for the height of one storey and 190mm for the rest of its height  |
| Exceeding 9m but not exceeding 12m  | Not exceeding 9m                   | 290mm from the base for the height of one storey and 190mm for the rest of its height  |
|                                     | Exceeding 9m but not exceeding 12m | 290mm from the base for the height of two storeys and 190mm for the rest of its height |

Section 2C: Thickness of walls in certain small buildings

- 2C11 Parapet walls:** The minimum thickness and maximum height of parapet walls should be as given in Diagram 4.
- 2C12 Single leaves of certain external walls:** The single leaf of external walls of small singlestorey non-residential buildings and of annexes need be only 90mm thick, notwithstanding paragraphs 2C38.
- 2C13 Modular bricks and blocks:** Where walls are constructed of bricks or blocks having modular dimensions derived from BS 6649:1985, wall thicknesses prescribed in this section which derive from a dimension of brick or block may be reduced by an amount not exceeding the deviation from work size permitted by a British Standard relating to equivalent sized bricks or blocks made of the same material.
- 2C14 Maximum floor area:** The guidance of this section assumes that no floor enclosed by structural walls on all sides exceeds 70m<sup>2</sup>, and that no floor without a structural wall on one side exceeds 36m<sup>2</sup>. (See Diagram 5.)
- 2C15 Imposed loads on roofs, floors and ceilings:** The design considerations given in this section are intended to be adequate for the imposed loads given in Table 4.
- 2C16 Maximum height of buildings:** The design guidance in this section is based on BS 6399-2:1997. The maximum heights of buildings given in Table c of Diagram 7 correlate to various site exposure conditions and wind speeds. A map showing wind speeds is given in Figure 1 of Diagram 6.

Diagram 4 Parapet walls: height

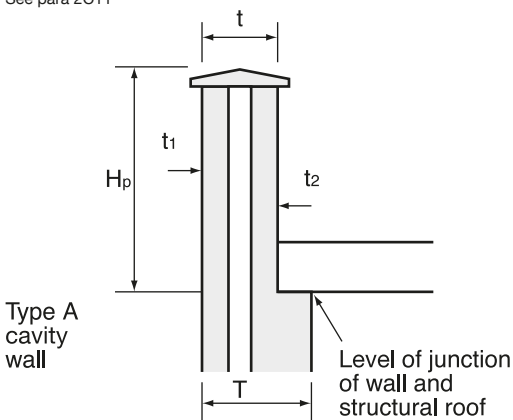
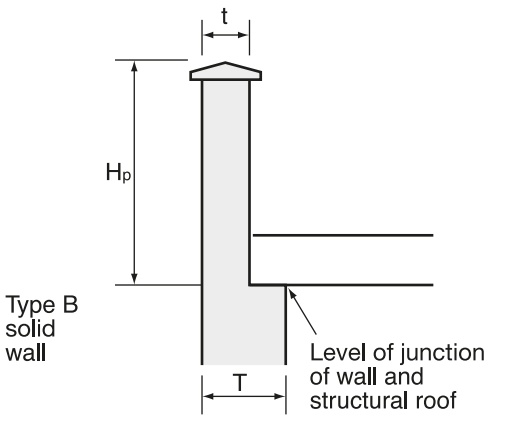
| See para 2C11   | Wall type | Thickness (mm)  | Parapet height $H_p$ to be not more than (mm) |
|---|-----------|---|---|
|  <p>Type A cavity wall</p> |           | $t_1 + t_2$<br>equal or less than 200                     | 600   |
|   |           | $t_1 + t_2$<br>greater than 200<br>equal or less than 250 | 860   |
|  <p>Type B solid wall</p>  |           | $t = 150$   | 600   |
|   |           | $t = 190$   | 760   |
|   |           | $t = 215$   | 860   |
| Note: t should be less than or equal to T   |           |   |   |

## Conditions relating to the wall

**2C17 Maximum allowable length and height of the wall:** This section does not deal with walls longer than 12m, measured from centre to centre of buttressing walls, piers or chimneys providing restraint, or with walls exceeding 12m in height (see also Table 3).

**2C18 Rules of measurement for heights of walls and storeys:** The height of a wall or a storey should be measured in accordance with the rules in Diagram 8.

Diagram 5 **Maximum floor area enclosed by structural walls**

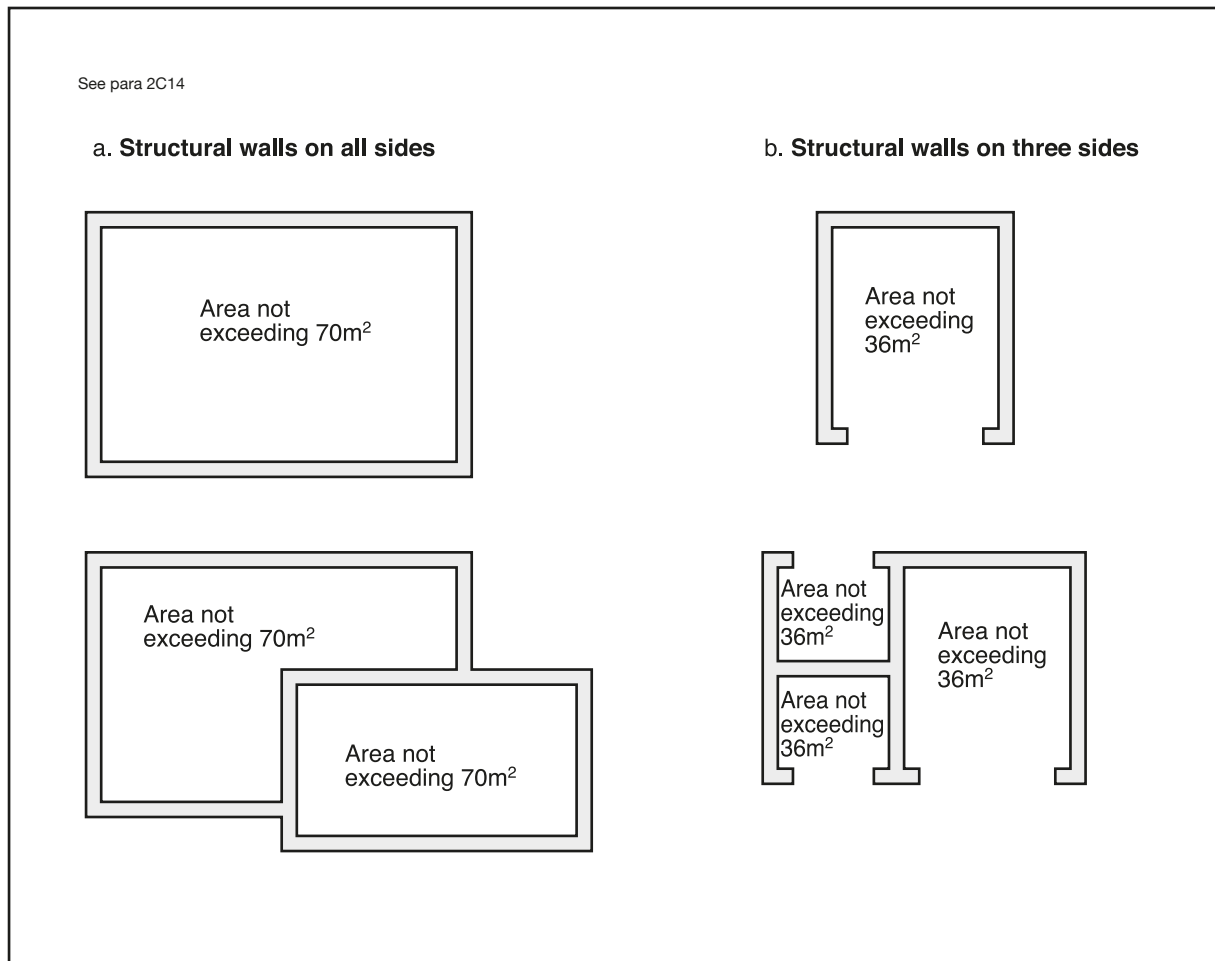



**Table 4 Imposed loads**

| Element  | Loading   |
|----------|---|
| Roof     | Distributed loads<br>1.00kN/m <sup>2</sup> for spans not exceeding 12m<br>1.5kN/m <sup>2</sup> for spans not exceeding 6m |
| Floors   | Distributed load: 2.00kN/m <sup>2</sup>   |
| Ceilings | Distributed load: 0.25kN/m <sup>2</sup><br>together with concentrated load: 0.9kN   |

## Construction materials and workmanship

**2C19 Wall ties:** Wall ties should either comply with BS 1243, DD 140, or BS EN 845-1 and should be material references 1 or 3 in BS EN 845 Table A 1 austenitic stainless steel. Wall ties should be selected in accordance with Table 5 of this Approved Document.

**2C20 Masonry units:** Walls should be properly bonded and solidly put together with mortar and constructed of masonry units conforming to:

- (a) clay bricks or blocks to BS 3921:1985 or BS 6649:1985 or BS EN 771-1;
- (b) calcium silicate bricks to BS 187:1978 or BS 6649:1985 or BS EN 771-2;
- (c) concrete bricks or blocks to BS 6073-1:1981 or BS EN 771-3 or -4;
- (d) square dressed natural stone to the appropriate requirements described in BS EN 771-6 or BS 5628-3:2001;
- (e) manufactured stone to BS 6457:1984 or BS EN 771-5.

**2C21 Compressive strength of masonry units:** Minimum compressive strength requirements for masonry units according to BS EN Standards are given in Diagram 9, where the masonry units indicated for Conditions A, B and C should have declared compressive strengths of not less than the values given in Table 6. Normalised compressive strengths for block sized clay and calcium silicate masonry units not complying with brick dimensional format are given in Table 7.

Section 2C: Thickness of walls in certain small buildings

Diagram 6 Map showing wind speeds in m/s for maximum height of buildings

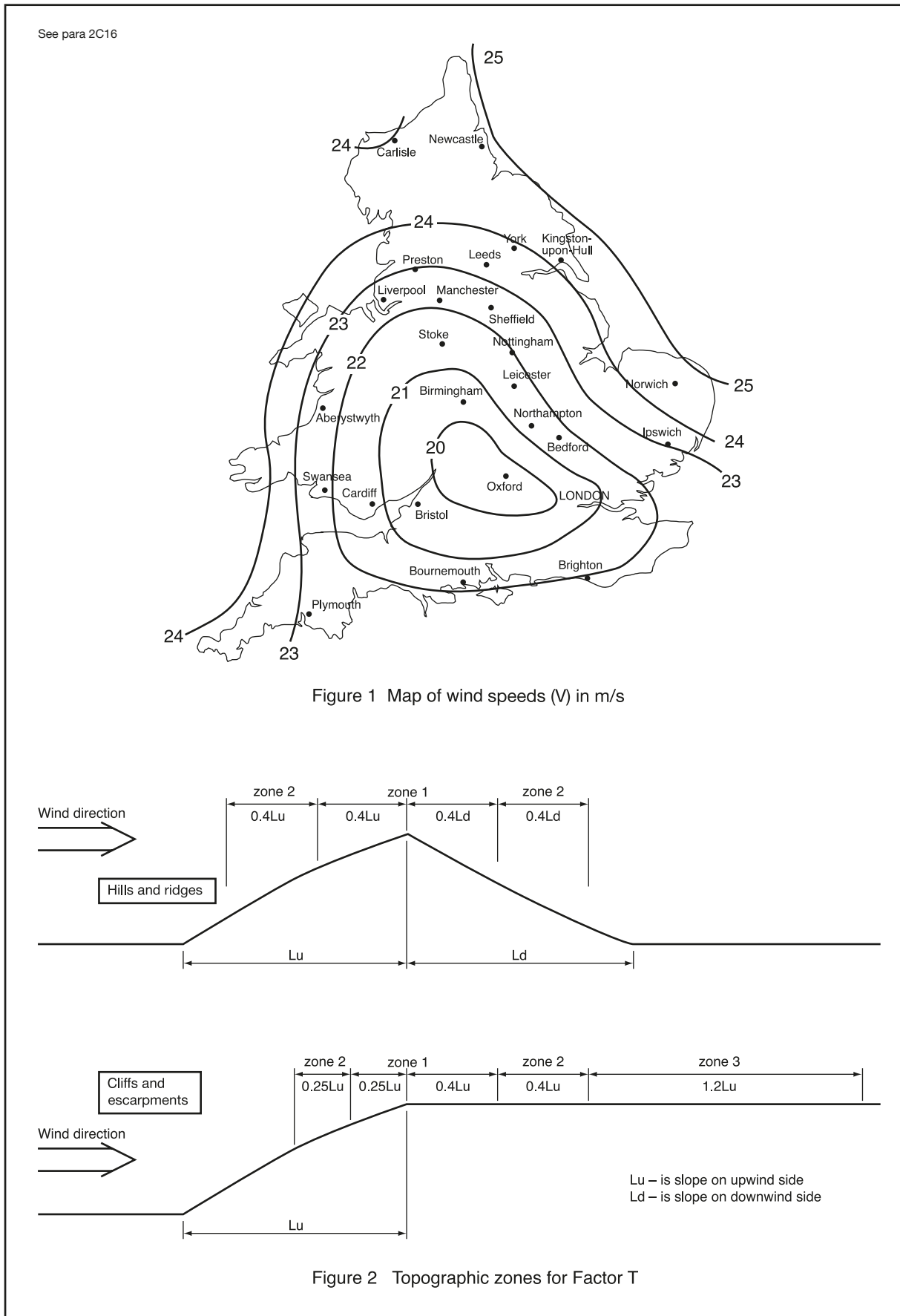

Section 2C: Thickness of walls in certain small buildings

### Diagram 7 Maximum height of buildings

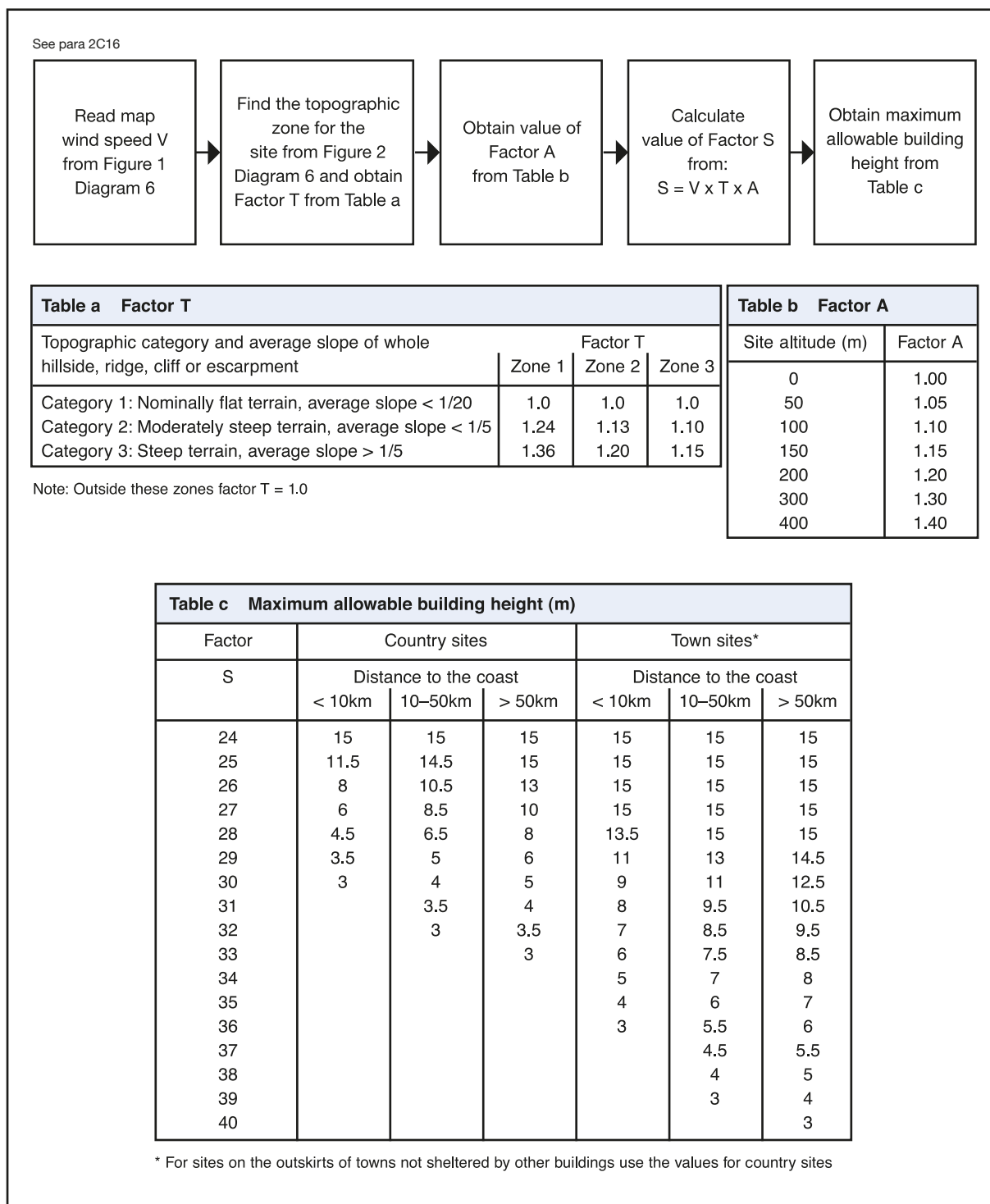

Section 2C: Thickness of walls in certain small buildings

Diagram 8 Measuring storey and wall heights

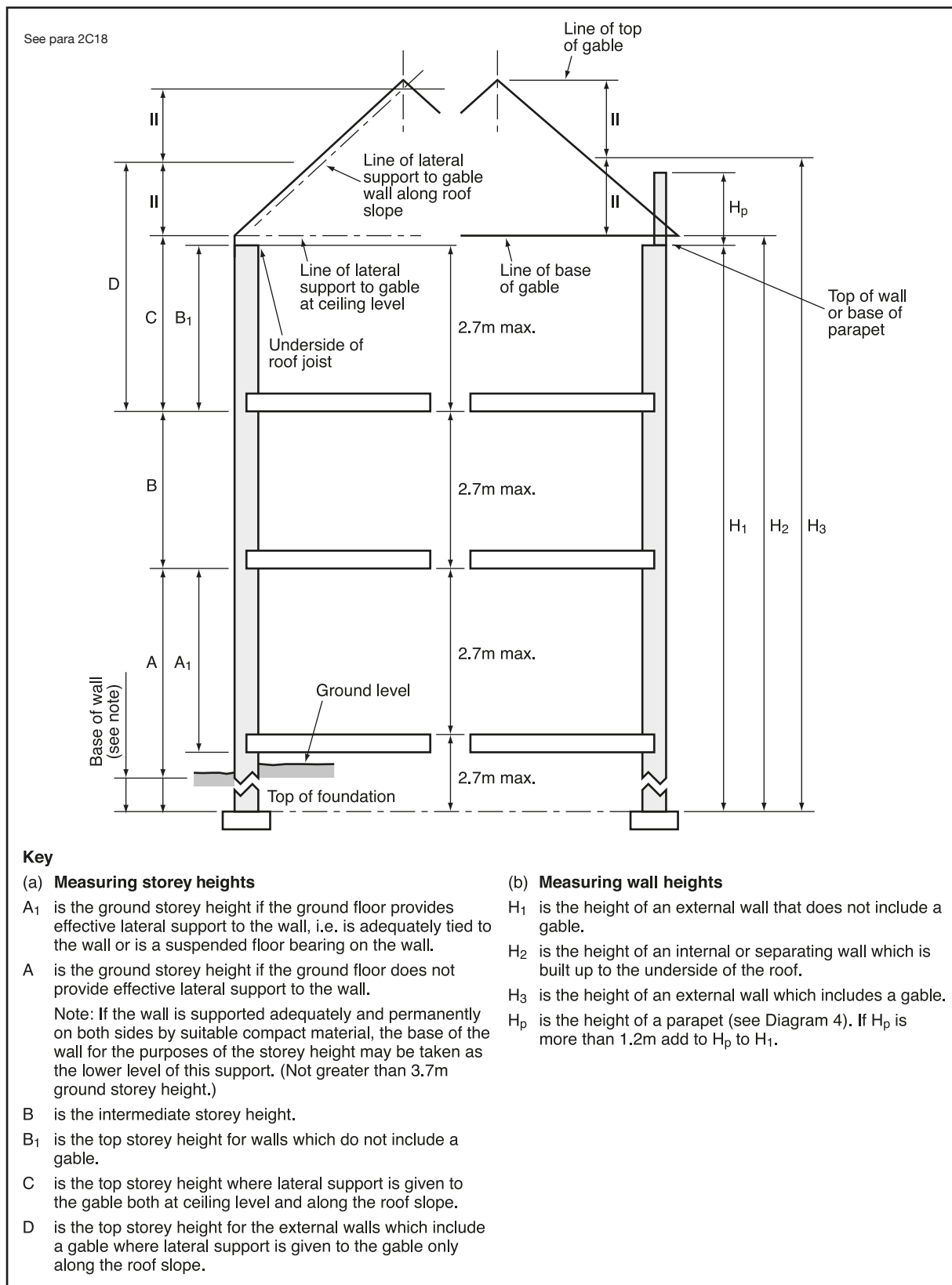

Section 2C: Thickness of walls in certain small buildings

**Table 5** Cavity wall ties

| Nominal cavity width mm (Note 1) | Permissible type of tie |  |  |
|----------------------------------|-------------------------|--|--|
|                                  | Tie length mm (Note 2)  | Tie shape in accordance with BS 1243*        | BS EN 845-1 tie (Note 4)   |
| 50 to 75                         | 200                     | Butterfly, double triangle or vertical twist | Types 1, 2, 3 or 4 to DD 140-2* and selected on the basis of the design loading and design cavity width.   |
| 76 to 90                         | 225                     | Double triangle or vertical twist            |  |
| 91 to 100                        | 225                     | Double triangle (Note 3) or vertical twist   | *Although BS 1243 and DD 140-2 were due to be withdrawn on 1 February 2005, the tie user classes (types) given in Tables 1 and 3 of the latter document can continue to be used after this date. |
| 101 to 125                       | 250                     | Vertical twist                               |  |
| 126 to 150                       | 275                     | Vertical twist                               |  |
| 151 to 175                       | 300                     | Vertical twist                               |  |
| 176 to 300                       | (See Note 2)            | Vertical twist style                         |  |

**Notes:**

- Where face insulated blocks are used the cavity width should be measured from the face of the masonry unit.
- The embedment depth of the tie should not be less than 50mm in both leaves. For cavities wider than 180mm calculate the length as the structural cavity width plus 125mm and select the nearest stock length.
- Double triangle ties of this shape having a strength to satisfy Type 2 of DD 140-2\* are manufactured. Specialist tie manufacturers should be consulted if 225mm long double triangle format ties are needed for 91 to 100mm cavities.
- Where BS EN 845-1 ties are used reference needs to be made additionally to DD 140-2\* for the selection of the type (i.e. type 1, 2, 3 or 4) relevant to the performance levels given in DD 140-2.

**Table 6** Declared compressive strength of masonry units complying with BS EN 771-1 to -5 (N/mm<sup>2</sup>)

| Masonry unit                       | Clay masonry units to BS EN 771-1 |                 | Calcium silicate masonry units to BS EN 771-2 |                 | Aggregate concrete masonry units to BS EN 771-3 | Autoclaved aerated conc. masonry units to BS EN 771-4 | Manufactured stone masonry units to BS EN 771-5                                  |  |
|------------------------------------|-----------------------------------|-----------------|---|-----------------|---|---|--|--|
| <b>Condition A (See Diagram 9)</b> |                                   |                 |   |                 |   |   |  |  |
| Brick                              | Group 1<br>6.0                    | Group 2<br>9.0  | Group 1<br>6.0                                | Group 2<br>9.0  | 6.0   | -   | Any unit complying with BS EN 771-5 will be acceptable for conditions A, B and C |  |
| Block                              | See Table 7                       | See Table 7     | See Table 7                                   | See Table 7     | 2.9*  | 2.9   |  |  |
| <b>Condition B (See Diagram 9)</b> |                                   |                 |   |                 |   |   |  |  |
| Brick                              | Group 1<br>9.0                    | Group 2<br>13.0 | Group 1<br>9.0                                | Group 2<br>13.0 | 9.0   | -   |  |  |
| Block                              | See Table 7                       | See Table 7     | See Table 7                                   | See Table 7     | 7.3*  | 7.3   |  |  |
| <b>Condition C (See Diagram 9)</b> |                                   |                 |   |                 |   |   |  |  |
| Brick                              | Group 1<br>18.0                   | Group 2<br>25.0 | Group 1<br>18.0                               | Group 2<br>25.0 | 18.0  | -   |  |  |
| Block                              | See Table 7                       | See Table 7     | See Table 7                                   | See Table 7     | 7.3*  | 7.3   |  |  |

\* These values are dry strengths to BS EN 772-1

**Notes:**

- This table applies to Group 1 and Group 2 units.
- For the EN 771 series of standards for masonry units the values of declared compressive strengths (N/mm<sup>2</sup>) given in Table 6 are mean values.
- Brick: a masonry unit having work sizes not exceeding 337.5mm in length or 112.5mm in height.
- Block: a masonry unit exceeding either of the limiting work sizes of a brick and with a minimum height of 190mm. For blocks with smaller heights, excluding cuts or make up units, the strength requirements are as for brick except for solid external walls where the blocks should have a compressive strength at least equal to that shown for block for an inner leaf of a cavity wall in the same position.
- Group 1 masonry units have not more than 25% formed voids (20% for frogged bricks). Group 2 masonry units have formed voids greater than 25%, but not more than 55%.

Section 2C: Thickness of walls in certain small buildings

Diagram 9 Declared compressive strength of masonry units

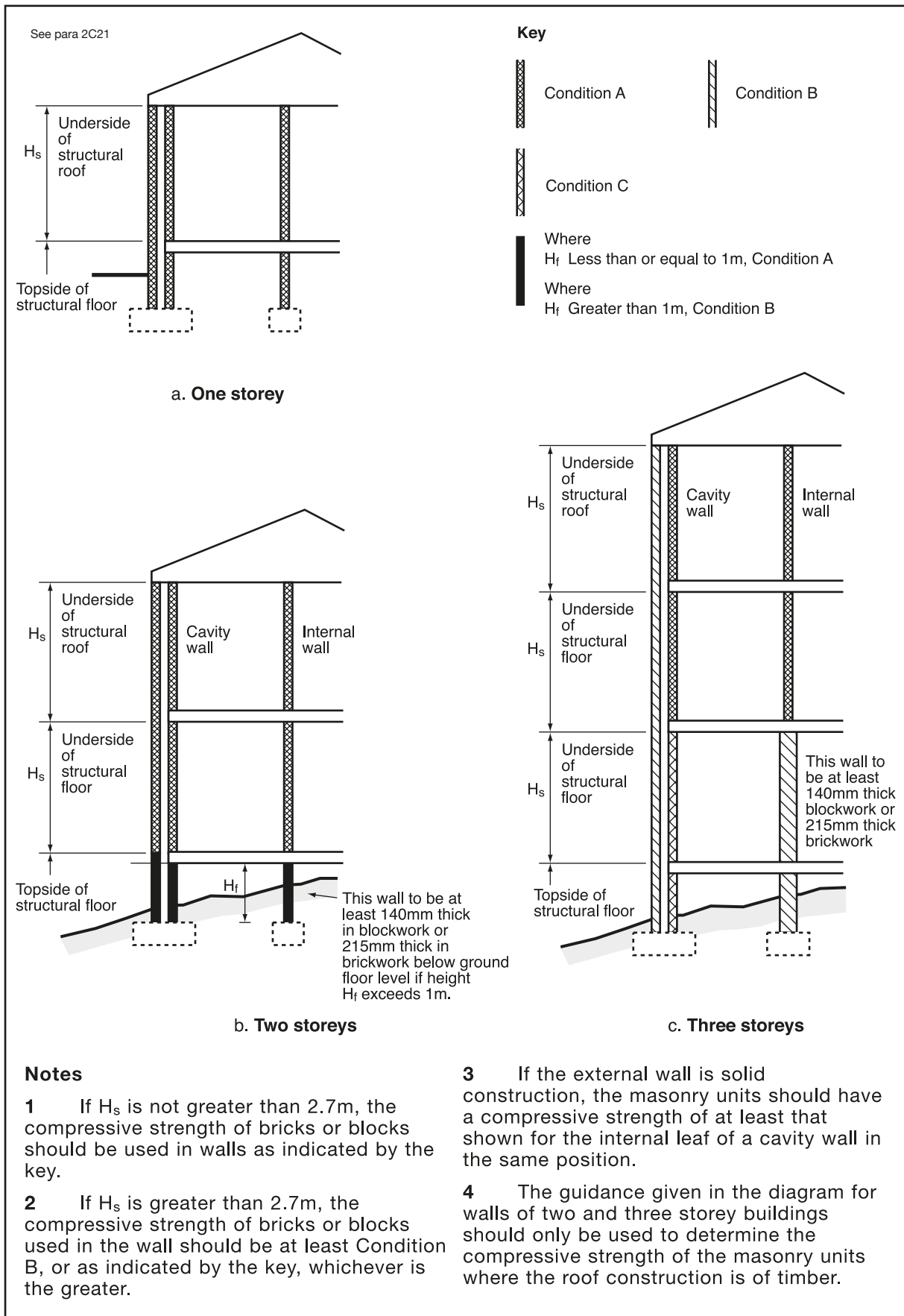

Section 2C: Thickness of walls in certain small buildings

**Table 7** Normalised compressive strength of masonry units of clay and calcium silicate blocks complying with BS EN 771-1 and 2 (N/mm<sup>2</sup>)

| Standard                                      | Condition (See Diagram 9) | Group 1 masonry units | Group 2 masonry units |
|---|---------------------------|-----------------------|-----------------------|
| Clay masonry units to BS EN 771-1             | A                         | 5.0                   | 8.0                   |
| Calcium silicate masonry units to BS EN 771-2 | B                         | 7.5                   | 11.0                  |
|   | C                         | 15.0                  | 21.0                  |

**Notes:**

1. Values in this table are normalised compressive strengths (N/mm<sup>2</sup>). Compressive strengths of masonry units should be derived according to EN 772-1.
2. The table applies to clay and calcium silicate block masonry units where the work size exceeds 337.5mm in length or 112.5mm in height.
3. Group 1 masonry units have not more than 25% formed voids (20% for frogged bricks). Group 2 masonry units have formed voids greater than 25%, but not more than 55%.

**2C22 Mortar:** Mortar should be:

- (a)
  - (i) Mortar designation (iii) according to BS BS 5628-3:2001.
  - (ii) Strength class M4 according to BS EN 998-2.
  - (iii) 1:1:5 or 6 CEM 1, lime and fine aggregate measured by volume of dry materials, or
- (b) of equivalent or greater strength and durability to the specification in a. above.

**Loading on walls**

**2C23 Maximum span of floors:** The maximum span for any floor supported by a wall is 6m where the span is measured centre to centre of bearing (see Diagram 10).

**2C24 Other loading conditions:**

- (a) Vertical loading on walls should be distributed. This may be assumed for concrete floor slabs, precast concrete floors, and timber floors designed in accordance with section 2B, and where the bearing length for lintels is 150mm or greater. Where a lintel has a clear span of 1200mm or less the bearing length may be reduced to 100mm.
- (b) Differences in level of ground or other solid construction between one side of the wall and the other should be less than 4 times the thickness of the wall as shown in Diagram 11.
- (c) The combined dead and imposed load should not exceed 70kN/m at base of wall (see Diagram 11).
- (d) Walls should not be subjected to lateral load other than from wind, and that covered by paragraph **2C24(b)**.

## Diagram 10 Maximum span of floors

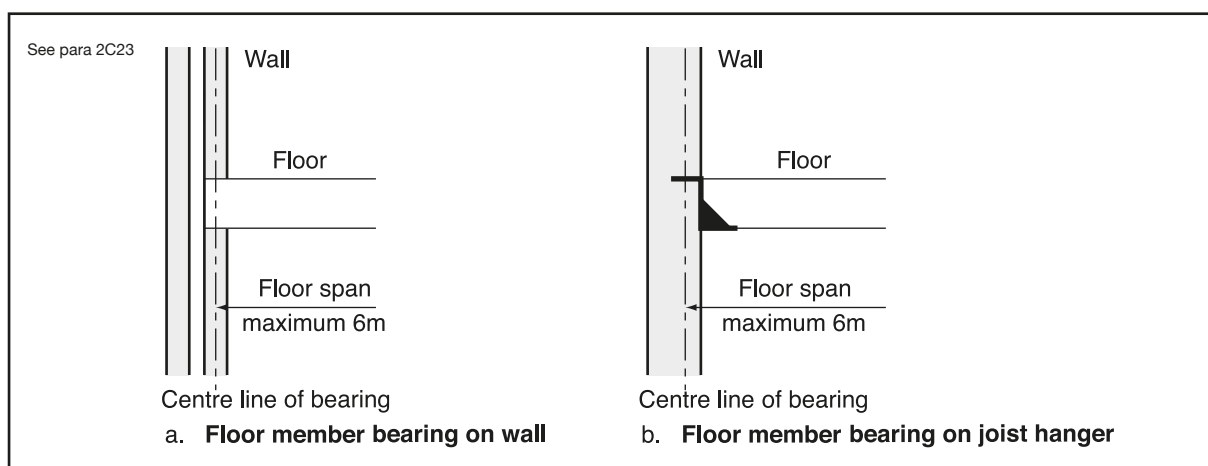

## End restraint

### 2C25 Vertical Lateral Restraint to Walls

The ends of every wall should be bonded or otherwise securely tied throughout their full height to a buttressing wall, pier or chimney. Long walls may be provided with intermediate buttressing walls, piers or chimneys dividing the wall into distinct lengths within each storey; each distinct length is a supported wall for the purposes of this section. The intermediate buttressing walls, piers or chimneys should provide lateral restraint to the full height of the supported wall, but they may be staggered at each storey.

### 2C26 Buttressing Walls

If the buttressing wall is not itself a supported wall its thickness  $T_2$  should not be less than:

- (a) half the thickness required by this section for an external or separating wall of similar height and length less 5mm; or
- (b) 75mm if the wall forms part of a dwelling house and does not exceed 6m in total height and 10m in length; and
- (c) 90mm in other cases.

The length of the buttressing wall should be at least  $1/6$  of the overall height of the supported wall and be bonded or securely tied to the supporting wall and at the other end to a buttressing wall, pier or chimney.

The size of any opening in the buttressing wall should be restricted as shown in Diagram 12.

### 2C27 Design criteria for piers and chimneys providing restraint:

- (a) piers should measure at least 3 times the thickness of the supported wall and chimneys twice the thickness, measured at right angles to the wall. Piers should have a minimum width of 190mm (see Diagram 13);
- (b) the sectional area on plan of chimneys (excluding openings for fireplaces and flues) should be not less than the area required for a pier in the same wall, and the overall thickness should not be less than twice the required thickness of the supported wall (see Diagram 13).



Section 2C: Thickness of walls in certain small buildings

Diagram 11 Differences in ground levels

See para 2C24b

a. Situations where differences in level may occur

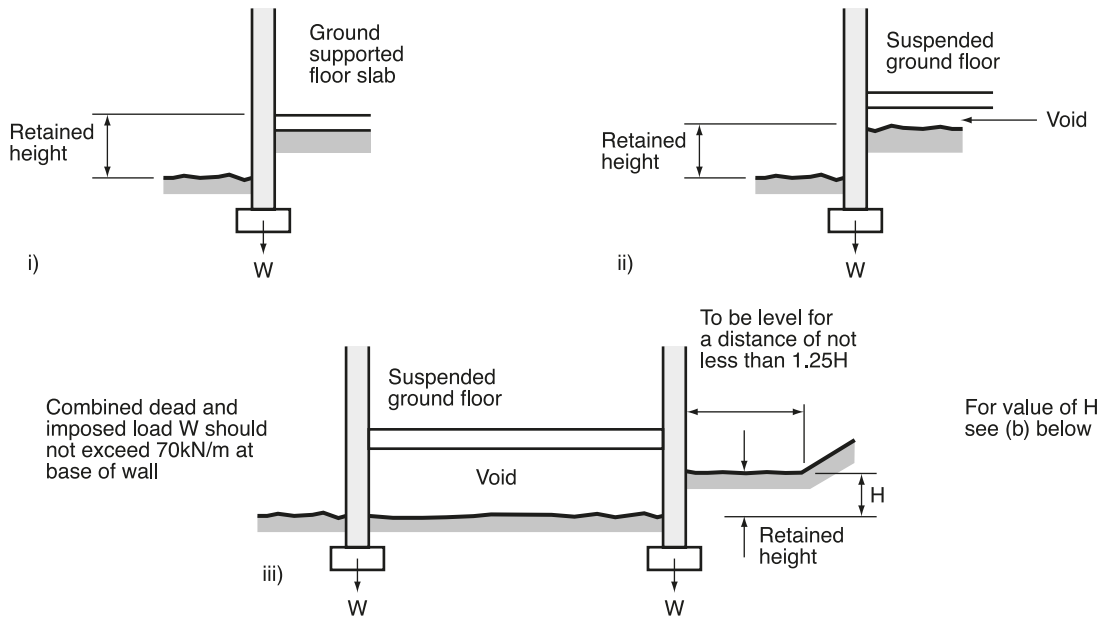

b. Maximum differences in permitted level

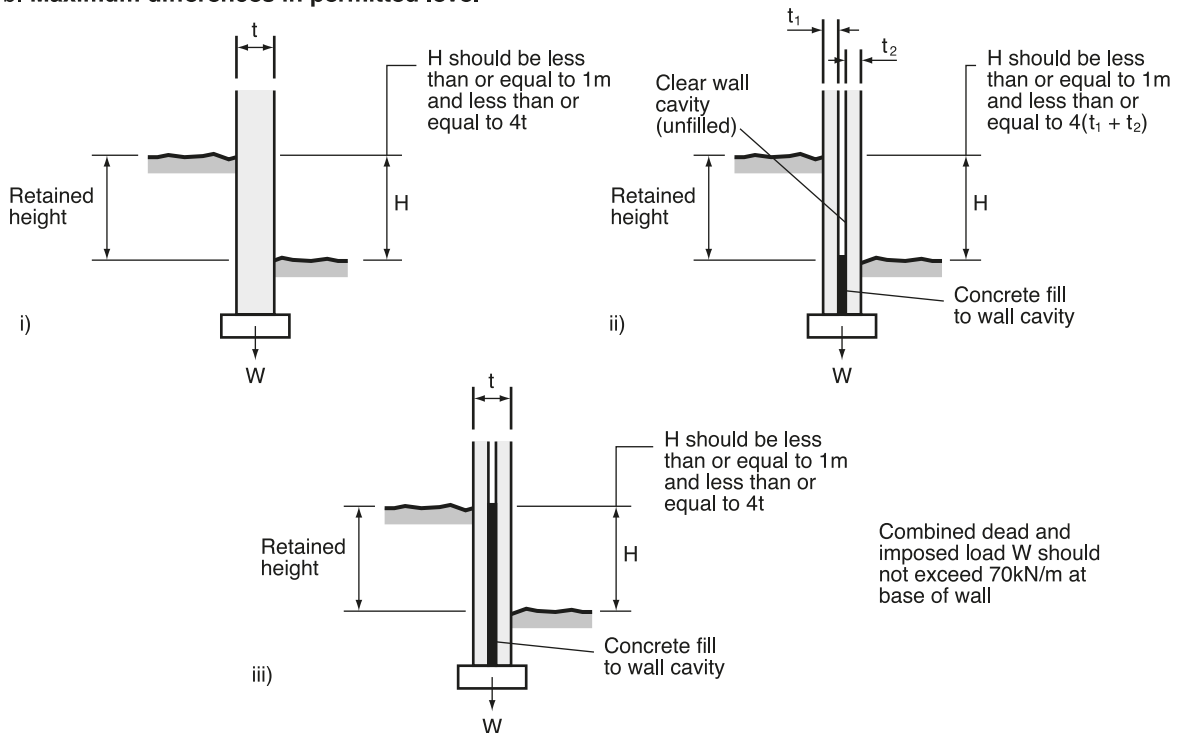

Notes

1 Floor slabs in figure b have been omitted for clarity and may be on either side of the walls shown.

2 Cavity walls should be tied in accordance with Table 5.

3 These recommendations apply only to circumstances where there is a full storey height of masonry above the upper retained level.

## Diagram 12 Openings in a buttressing wall

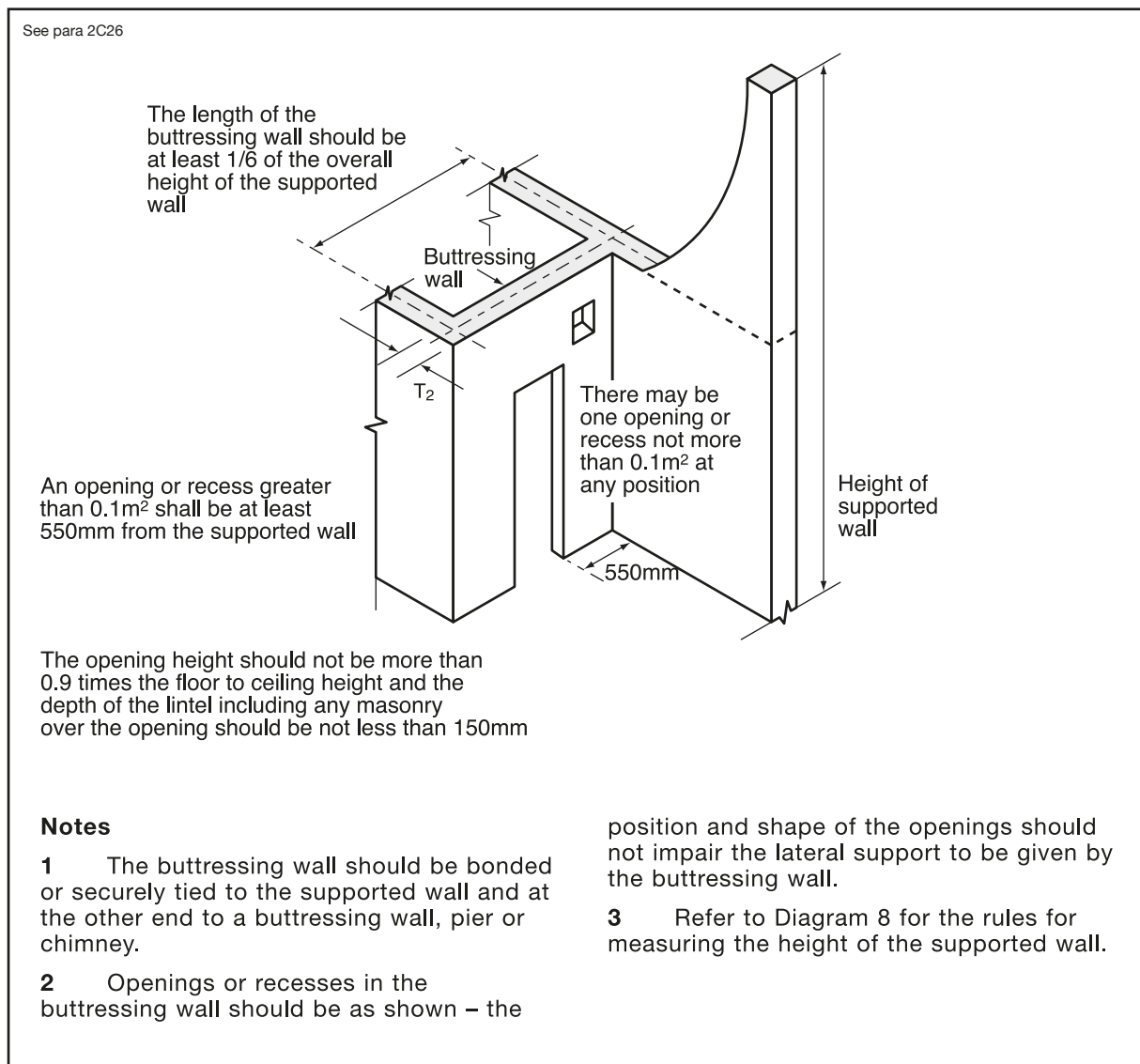

## Openings, recesses, overhangs and chases

### 2C28 General:

The number, size and position of openings and recesses should not impair the stability of a wall or the lateral restraint afforded by a buttressing wall to a supported wall. Construction over openings and recesses should be adequately supported.

### 2C29 Dimensional criteria for openings and recesses:

The dimensional criteria are given in Diagram 14 and Table 8.

No openings should be provided in walls below ground floor except for small holes for services and ventilation, etc. which should be limited to a maximum area of  $0.1\text{m}^2$  at not less than 2m centres.

Section 2C: Thickness of walls in certain small buildings

**2C30 Chases:**

- (a) vertical chases should not be deeper than 1/3 of the wall thickness or, in cavity walls, 1/3 of the thickness of the leaf;
- (b) horizontal chases should not be deeper than 1/6 of the thickness of the leaf of the wall;
- (c) chases should not be so positioned as to impair the stability of the wall, particularly where hollow blocks are used.

**2C31 Overhangs:**

The amount of any projection should not impair the stability of the wall.

**Diagram 13 Buttrressing**

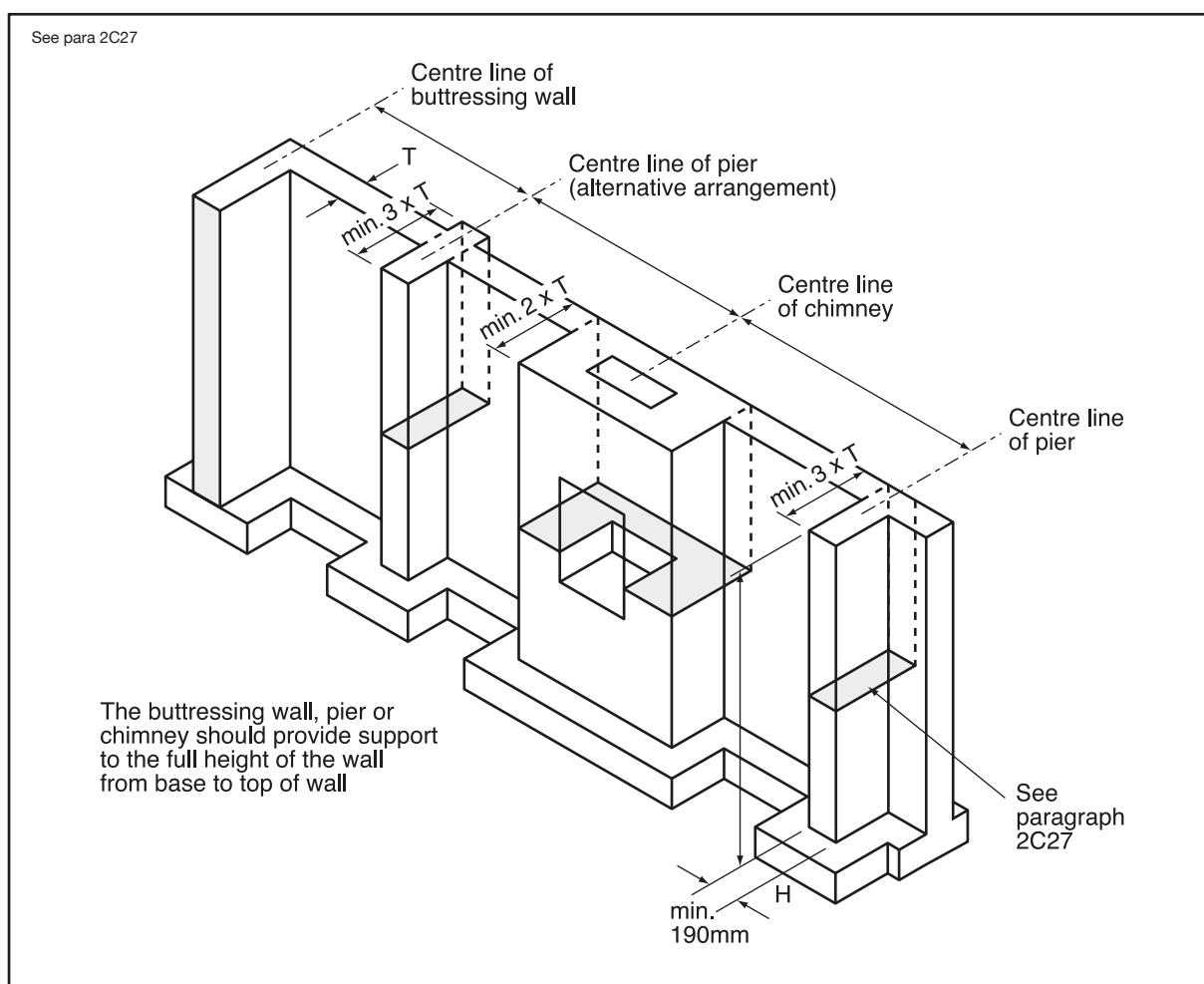

**Lateral support by roofs and floors**

**2C32** A wall in each storey of a building should extend to the full height of that storey, and have horizontal lateral supports to restrict movement of the wall at right angles to its plane.

**2C33 Floors and roofs should:**

- (a) act to transfer lateral forces from walls to buttressing walls, piers or chimneys; and
- (b) be secured to the supported wall by connections specified in paragraphs

Section 2C: Thickness of walls in certain small buildings

**2C34 and 2C35.**

**2C34** The requirements for lateral restraint of walls at roof and floor levels are given in Table 9 and guidance on satisfying the requirements is given in paragraphs **2C35** and **2C36**.

**2C35** Walls should be strapped to floors above ground level, at intervals not exceeding 2m and as shown in Diagram 15 by tension straps conforming to BS EN 845-1. For corrosion resistance purposes, the tension straps should be material reference 14 or 16.1 or 16.2 (galvanised steel) or other more resistant specifications including material references 1 or 3 (austenitic stainless steel). The declared tensile strength of tension straps should not be less than 8kN.

Tension straps need not be provided:

- (a) in the longitudinal direction of joists in houses of not more than 2 storeys, if the joists are at not more than 1.2m centres and have at least 90mm bearing on the supported walls or 75mm bearing on a timber wall-plate at each end, and
- (b) in the longitudinal direction of joists in houses of not more than 2 storeys, if the joists are carried on the supported wall by joist hangers in accordance with BS EN 845-1 of the restraint type described in BS 5628-1 and shown in Diagram 15(c), and are incorporated at not more than 2m centres, and
- (c) when a concrete floor has at least 90mm bearing on the supported wall (see Diagram 15(d)), and
- (d) where floors are at or about the same level on each side of a supported wall, and contact between the floors and wall is either continuous or at intervals not exceeding 2m. Where contact is intermittent, the points of contact should be in line or nearly in line on plan (see Diagram 15(e)).

**Diagram 14 Sizes of openings and recesses**

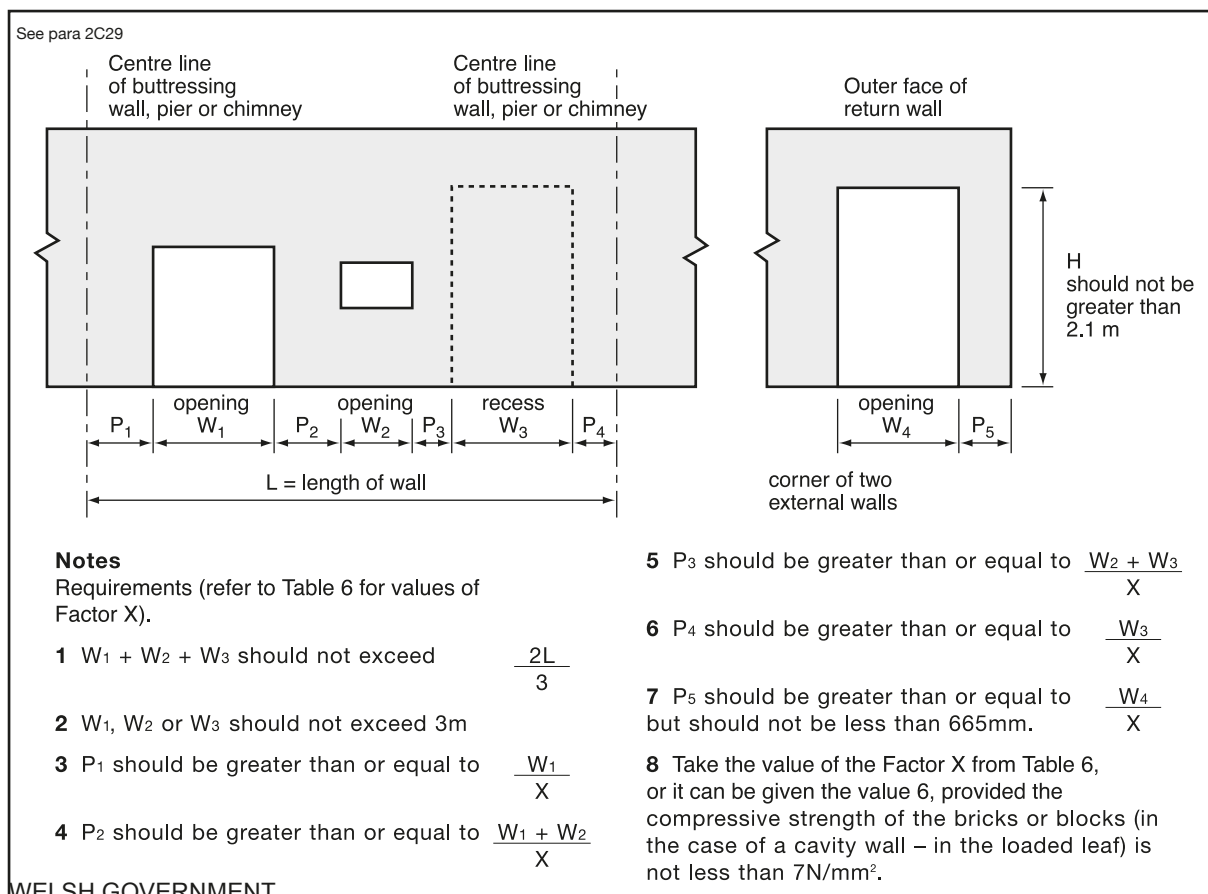

Section 2C: Thickness of walls in certain small buildings

**Table 8** Value of Factor 'X'

(see Diagram 14)

| Nature of roof span         | Maximum roof span (m) | Minimum thickness of wall inner (mm) | Span of floor is parallel to wall | Span of timber floor into wall |          | Span of concrete floor into wall |          |
|-----------------------------|-----------------------|--------------------------------------|-----------------------------------|--------------------------------|----------|----------------------------------|----------|
|                             |                       |                                      |                                   | max 4.5m                       | max 6.0m | max 4.5m                         | max 6.0m |
| Value of factor 'X'         |                       |                                      |                                   |                                |          |                                  |          |
| Roof spans parallel to wall | Not applicable        | 100                                  | 6                                 | 6                              | 6        | 6                                | 6        |
|                             |                       | 90                                   | 6                                 | 6                              | 6        | 6                                | 5        |
| Timber roof spans into wall | 9                     | 100                                  | 6                                 | 6                              | 5        | 4                                | 3        |
|                             |                       | 90                                   | 6                                 | 4                              | 4        | 3                                | 3        |

**Table 9** Lateral support for walls

| Wall type   | Wall length     | Lateral support required  |
|---|-----------------|---|
| Solid or cavity: external compartment separating                        | Any length      | Roof lateral support by every roof forming a junction with the supported wall   |
|   | Greater than 3m | Floor lateral support by every floor forming a junction with the supported wall |
| Internal load-bearing wall (not being a compartment or separating wall) | Any length      | Roof or floor lateral support at the top of each storey                         |

**2C36** Gable walls should be strapped to roofs as shown in Diagram 16(a) and (b) by tension straps as described in **2C35**.

Vertical strapping at least 1m in length should be provided at eaves level at intervals not exceeding 2m as shown in Diagram 16(c) and (d). Vertical strapping may be omitted if the roof:

- (a) has a pitch of 15° or more, and
- (b) is tiled or slated, and
- (c) is of a type known by local experience to be resistant to wind gusts, and
- (d) has main timber members spanning onto the supported wall at not more than 1.2m centres.

## Diagram 15 Lateral support by floors

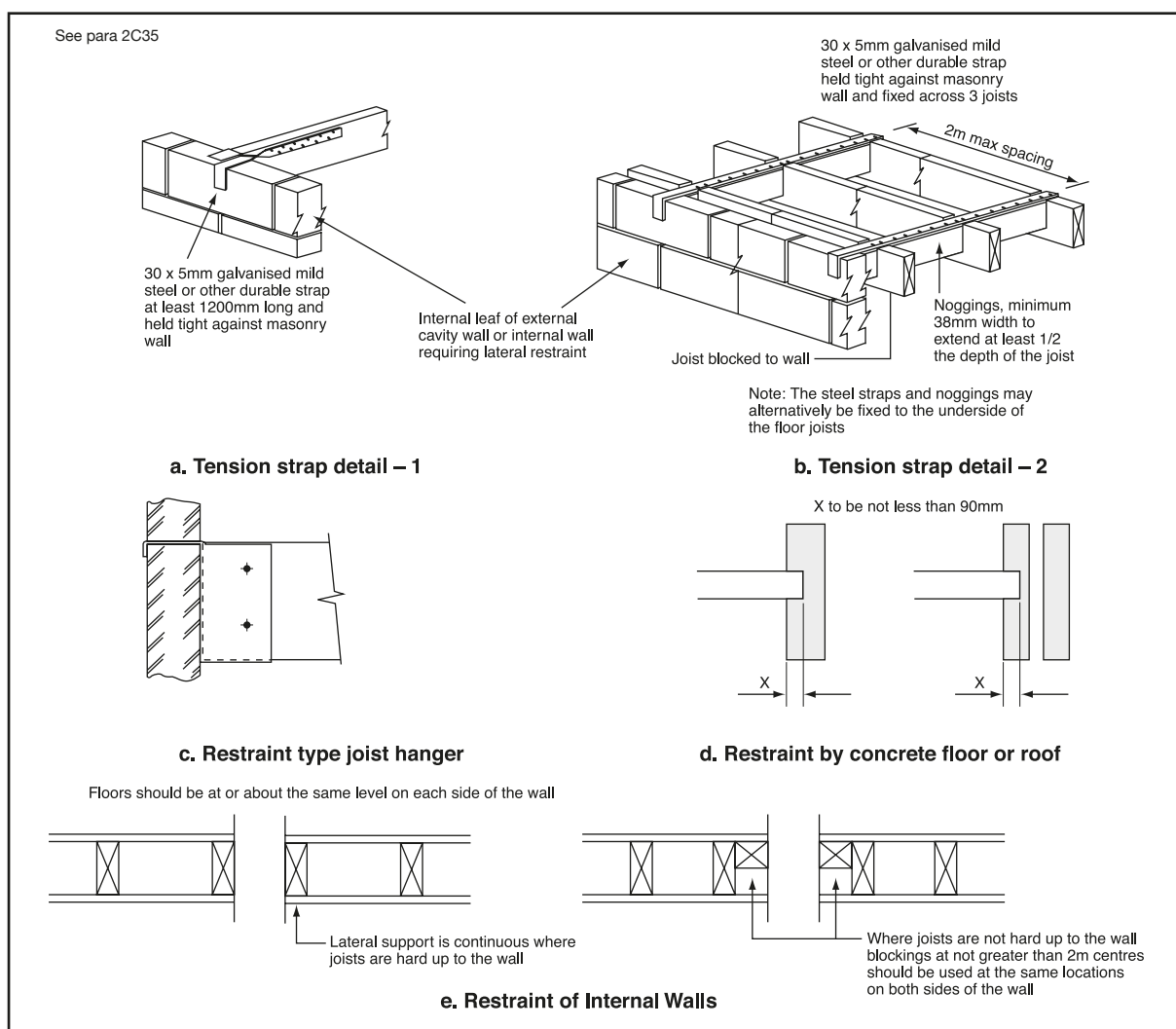

## Interruption of lateral support

**2C37** Where an opening in a floor or roof for a stairway or the like adjoins a supported wall and interrupts the continuity of lateral support, the following conditions should be satisfied for the purposes of Section 2C:

- the maximum permitted length of the opening is to be 3m, measured parallel to the supported wall, and
- where a connection is provided by means other than by anchor, this should be provided throughout the length of each portion of the wall situated on each side of the opening, and
- where a connection is provided by mild steel anchors, these should be spaced closer than 2m on each side of the opening to provide the same number of anchors as if there were no opening, and
- there should be no other interruption of lateral support.

## Small single-storey non-residential buildings and annexes

### 2C38 Size and proportion

#### (i) General

The guidance given applies in the following circumstances:

- (a) The floor area of the building or annexe does not exceed 36m<sup>2</sup>.
- (b) The walls are solidly constructed in brickwork or blockwork using materials which comply with paragraphs 2C19 to 2C22.
- (c) Where the floor area of the building or annexe exceeds 10m<sup>2</sup> the walls have a mass of not less than 130kg/m<sup>2</sup>.

**Note:** There is no surface mass limitation recommended for floor areas of 10m<sup>2</sup> or less.

- (d) Access to the roof is only for the purposes of maintenance and repair.
- (e) The only lateral loads are wind loads.

### Diagram 16 Lateral support at roof level

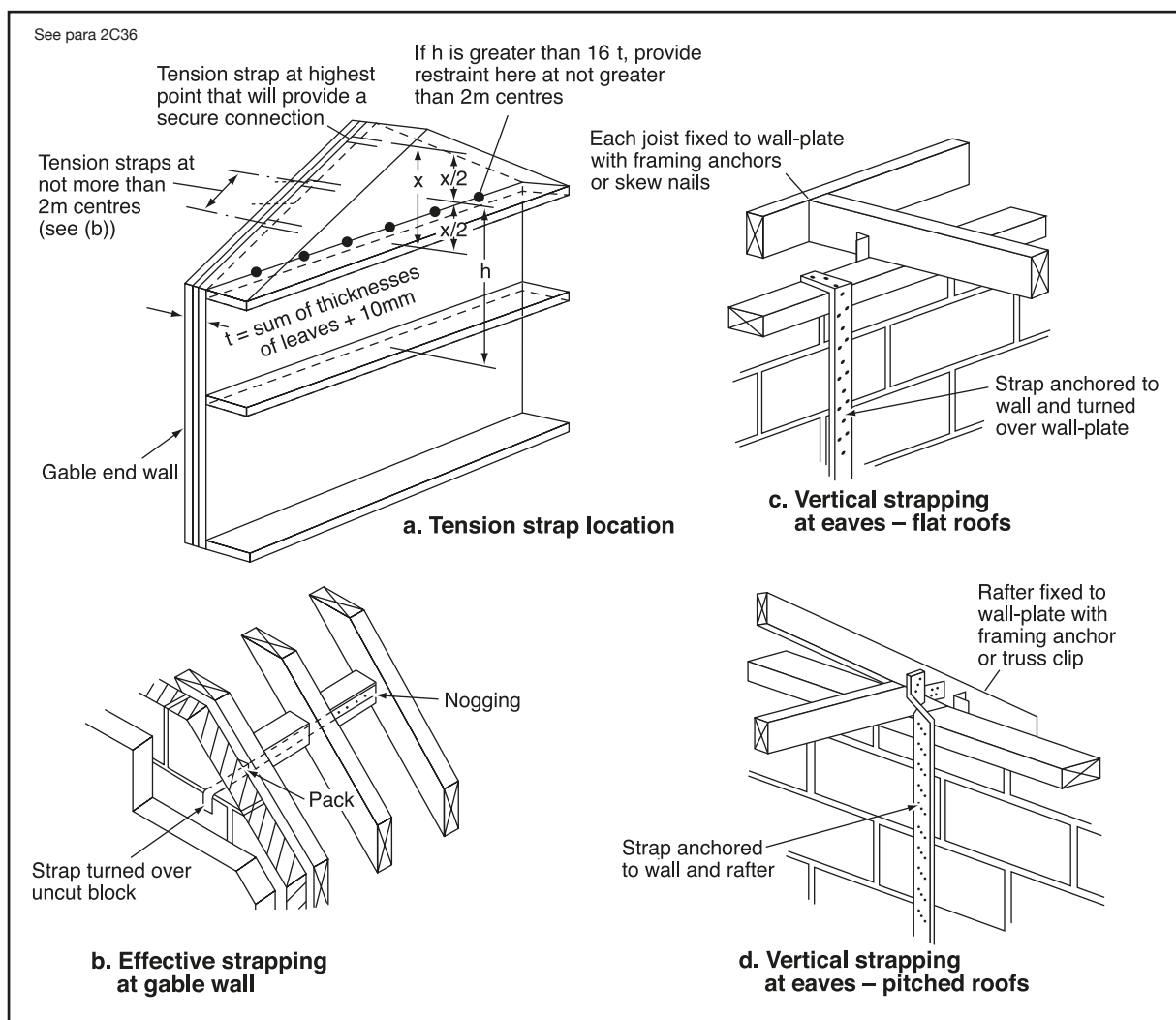

Section 2C: Thickness of walls in certain small buildings

- (f) The maximum length or width of the building or annexe does not exceed 9m.
- (g) The height of the building or annexe does not exceed the lower value derived from Diagram 2.
- (h) The roof is braced at rafter level, horizontally at eaves level and at the base of any gable by roof decking, rigid sarking or diagonal timber bracing, as appropriate, in accordance with BS 5268-3.
- (i) Walls are tied to the roof structure vertically and horizontally in accordance with paragraphs 2C32 to 2C36 and with horizontal lateral restraint at roof level in accordance with paragraph (iv) below.
- (j) The roof structure of an annexe is secured to the structure of the main building at both rafter and eaves level.

Diagram 17 Size and location of openings

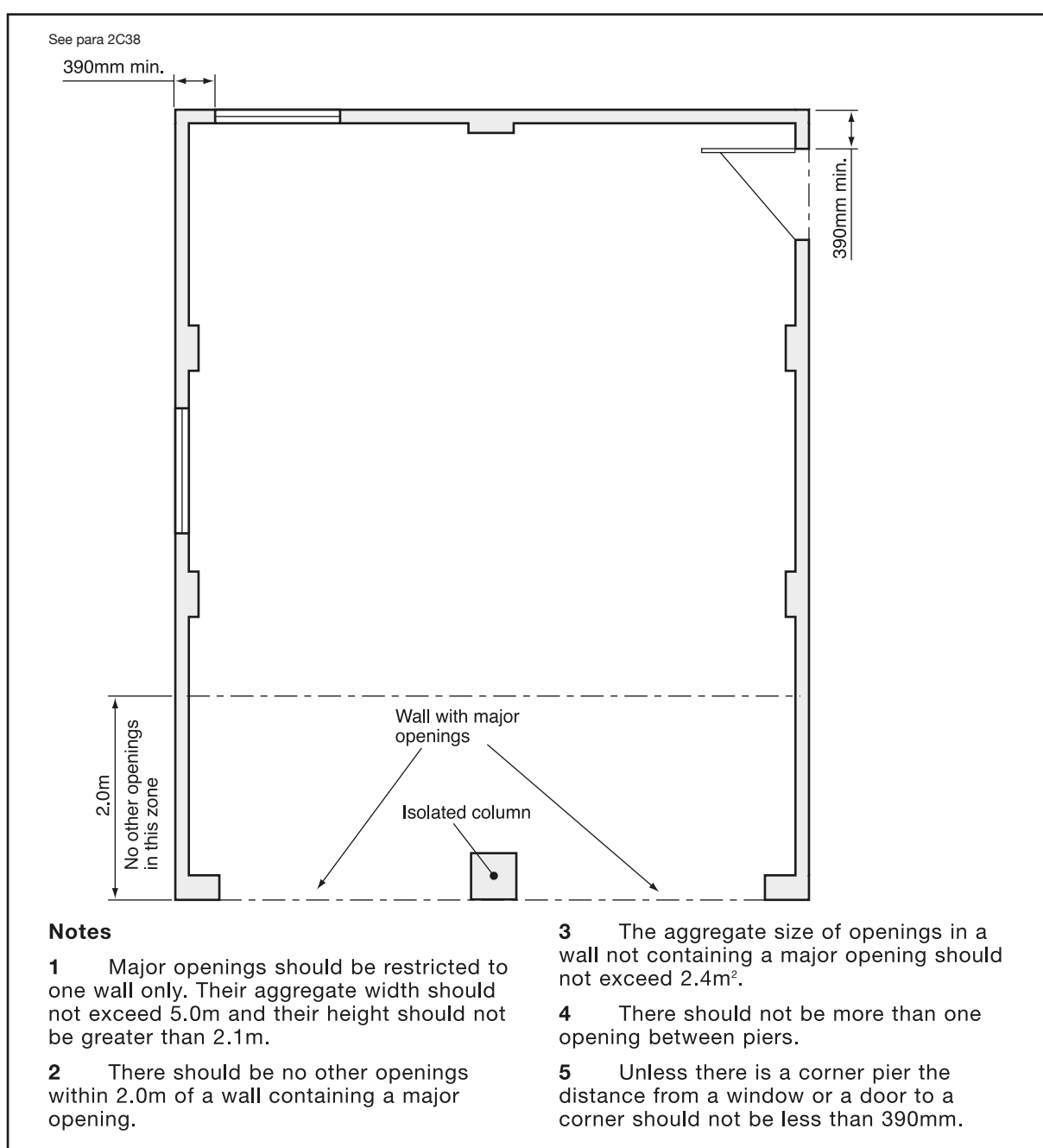



Section 2C: Thickness of walls in certain small buildings

**(ii) Size and location of openings**

One or two major openings not more than 2.1m in height are permitted in one wall of the building or annexe only. The width of a single opening or the combined width of two openings should not exceed 5m.

The only other openings permitted in a building or annexe are for windows and a single leaf door. The size and location of these openings should be in accordance with Diagram 17.

Diagram 18 Wall thickness

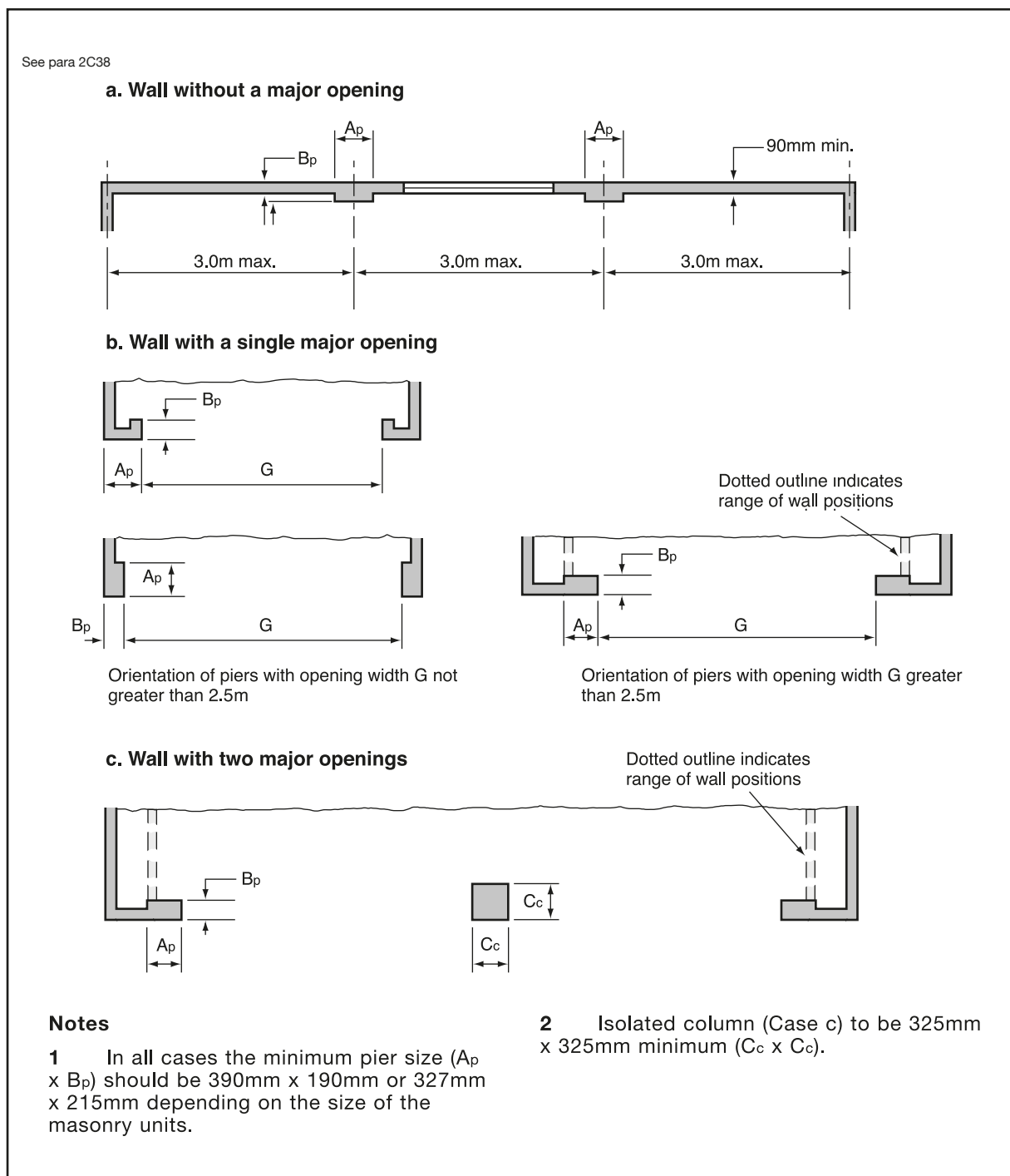

Section 2C: Thickness of walls in certain small buildings

**(iii) Wall thickness and recommendations for piers**

The walls should have a minimum thickness of 90mm.

Walls which do not contain a major opening but exceed 2.5m in length or height should be bonded or tied to piers for their full height at not more than 3m centres as shown in Diagram 18a. Walls which contain one or two major openings should in addition have piers as shown in Diagrams 18b and 18c. Where ties are used to connect piers to walls they should be flat, 20mm x 3mm in cross section, be in stainless steel in accordance with clause **2C19**, be placed in pairs and be spaced at not more than 300mm centre vertically.

**(iv) Horizontal lateral restraint at roof level Walls**

Should be tied horizontally at no more than 2m centres to the roof structure at eaves level, base of gables and along roof slopes as shown in Diagram 19 with straps fixed in accordance with paragraphs **2C35** and **2C36**. Where straps cannot pass through a wall they should be adequately secured to the masonry using suitable fixings. Isolated columns should also be tied to the roof structure (see Diagram 19).

Diagram 19 Lateral restraint at roof level

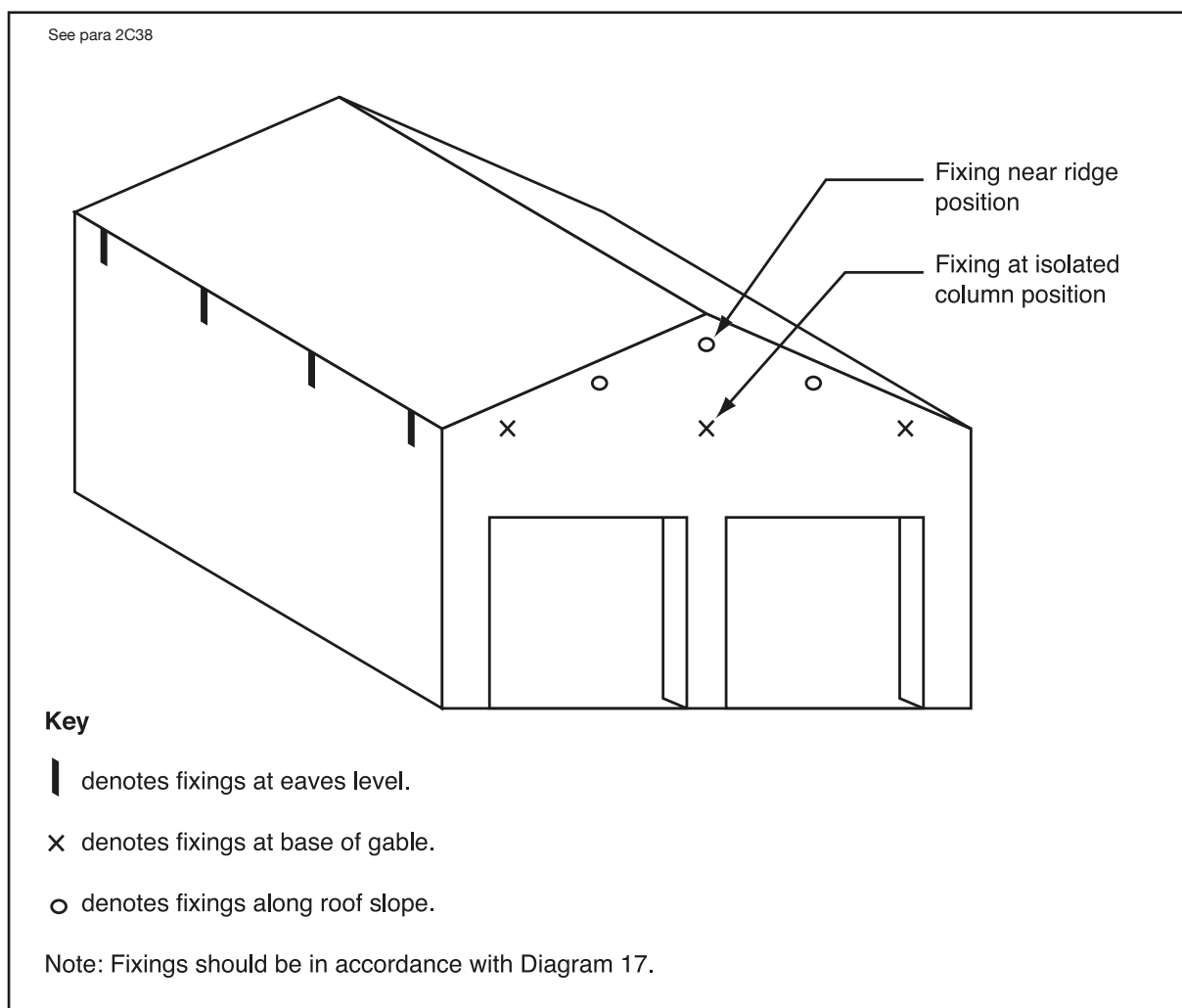

## Section 2D: Proportions for masonry chimneys above the roof surface

### Height to width relationship

**2D1** Where a chimney is not adequately supported by ties or securely restrained in any way, its height if measured from the highest point of intersection with the roof surface, gutter, etc. should not exceed  $4.5W$ , provided the density of the masonry is greater than  $1500\text{kg/m}^3$ , where:

**W** is the least horizontal dimension of the chimney measured at the same point of intersection, and

**H** is measured to the top of any chimney pot or other flue terminal (see Diagram 20).

Diagram 20 Proportions for masonry chimneys

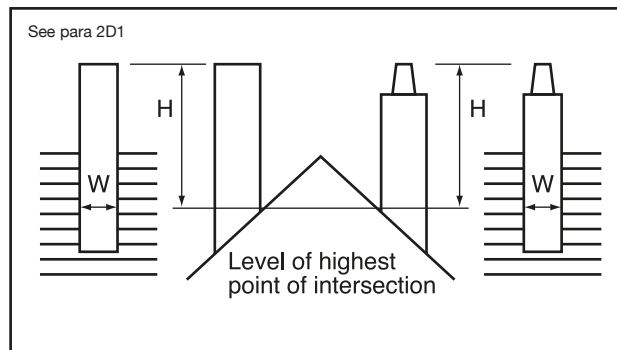

## Section 2E: Foundations of plain concrete

### Conditions relating to the ground

2E1 There should not be:

- (a) non-engineered fill (as described in BRE Digest 427) or wide variation in ground conditions within the loaded area; nor
- (b) weaker or more compressible ground at such a depth below the foundation as could impair the stability of the structure.

### Design provisions

2E2 The following design provisions relate to foundations:

- (a) the foundations should be situated centrally under the wall;
- (b) for foundations in chemically aggressive soil conditions guidance in BS 8500-1 and BRE Special Digest 1 should be followed. In non-aggressive soils, concrete should be composed of Portland cement to BS EN 197-1 and -2 and fine and coarse aggregate conforming to BS EN 12620 and the mix should comply with one of the following recommendations:
  - (i) in proportion of 50kg of Portland cement to not more than 200kg (0.1m<sup>3</sup>) of fine aggregate and 400kg (0.2m<sup>3</sup>) of coarse aggregate; or
  - (ii) grade ST2 or grade GEN I concrete to BS 8500-2;
- (c) minimum thickness T of concrete foundation should be 150mm or P, whichever is the greater where P is derived using Table 10 and Diagram 23. Trench fill foundations may be used as an acceptable alternative to strip foundations;
- (d) foundations stepped on elevation should overlap by twice the height of the step, by the thickness of the foundation, or 300mm, whichever is greater (see Diagram 21). For trench fill foundations the overlap should be twice the height of the step or 1m, whichever is greater;
- (e) steps in foundations should not be of greater height than the thickness of the foundation (see Diagram 21);
- (f) foundations for piers, buttresses and chimneys should project as indicated in Diagram 22 and the projection X should never be less than the value of P where there is no local thickening of the wall.

### Minimum width of strip foundations

2E3 The recommended minimum widths of foundations given in Table 10 may be used.

## Diagram 21 Elevation of stepped foundation

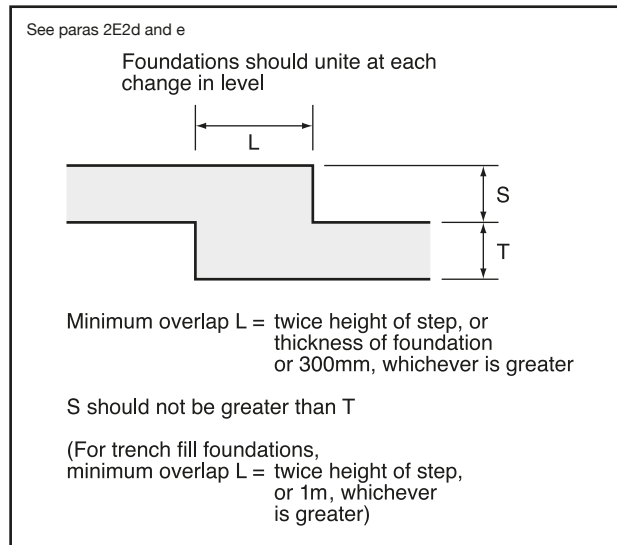

## Diagram 22 Piers and chimneys

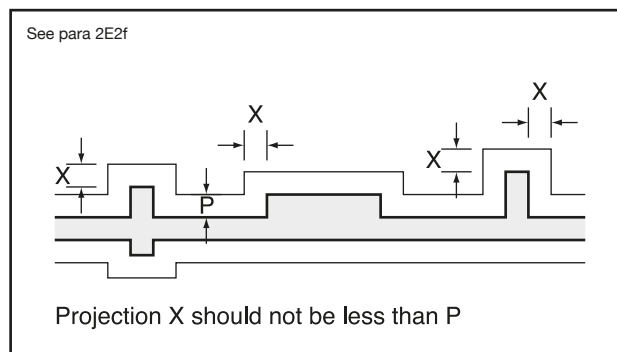

## Diagram 23 Foundation dimensions

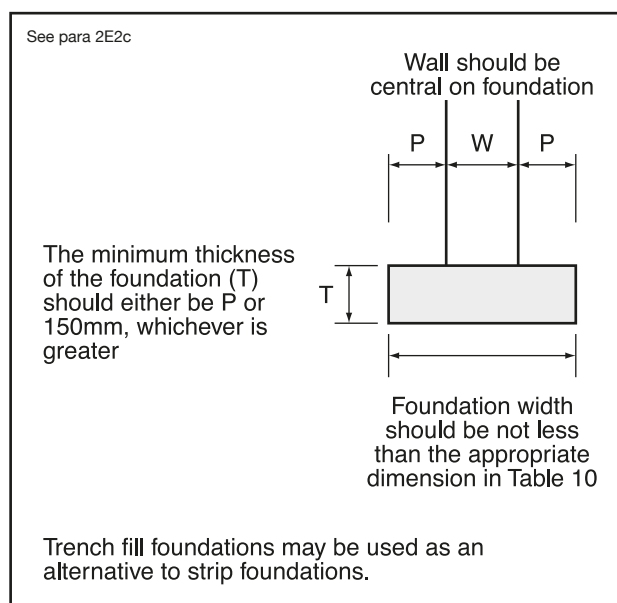

**Table 10 Minimum width of strip footings**

| Type of ground<br>(including<br>engineered fill)  | Condition<br>of ground                                   | Field test<br>applicable   | Total load of load-bearing walling<br>not more than (kN/linear metre) |     |  |     |     |     |
|---|--|--|---|-----|--|-----|-----|-----|
|   |  |  | 20  | 30  | 40   | 50  | 60  | 70  |
|   |  |  | Minimum width of strip foundations (mm)                               |     |  |     |     |     |
| I<br>Rock   | Not inferior to<br>sandstone, limestone<br>or firm chalk | Requires at least a pneumatic<br>or other mechanically<br>operated pick for excavation                   | In each case equal to the width of wall                               |     |  |     |     |     |
| II<br>Gravel or sand                              | Medium dense   | Requires pick for excavation.<br>Wooden peg 50mm square<br>in crosssection hard to drive<br>beyond 150mm | 250   | 300 | 400  | 500 | 600 | 650 |
| III<br>Clay<br>Sandy clay                         | Stiff<br>Stiff   | Can be indented slightly<br>by thumb   | 250   | 300 | 400  | 500 | 600 | 650 |
| IV<br>Clay<br>Sandy clay                          | Firm<br>Firm   | Thumb makes impression easily  | 300   | 350 | 450  | 600 | 750 | 850 |
| V<br>Sand<br>Silty sand<br>Clayey sand            | Loose<br>Loose<br>Loose                                  | Can be excavated with a spade.<br>Wooden peg 50mm square in<br>cross section can be easily driven        | 400   | 600 | Note:<br>Foundations on soil<br>types Vand VI do not fall<br>within the provisions of this<br>section if the total load<br>exceeds 30kN/m. |     |     |     |
| VI<br>Silt<br>Clay<br>Sandy clay<br>Clay or silt  | Soft<br>Soft<br>Soft<br>Soft                             | Finger pushed in up to 10mm  | 450   | 650 |  |     |     |     |
| VII<br>Silt<br>Clay<br>Sandy clay<br>Clay or silt | Very soft<br>Very soft<br>Very soft<br>Very soft         | Finger easily pushed in up to 25mm   | Refer to specialist advice  |     |  |     |     |     |

The table is applicable only within the strict terms of the criteria described within it.

### Minimum depth of strip foundations

**2E4** Except where strip foundations are founded on rock, the strip foundations should have a minimum depth of 0.45m to their underside to avoid the action of frost. This depth, however, will commonly need to be increased in areas subject to long periods of frost or in order to transfer the loading onto satisfactory ground. In clay soils subject to volume change on drying ('shrinkable clays', with Plasticity Index greater than or equal to 10%), strip foundations should be taken to a depth where anticipated ground movements will not impair the stability of any part of the building taking due consideration of the influence of vegetation and trees on the ground. The depth to the underside of foundations on clay soils should not be less than 0.75m, although this depth will commonly need to be increased in order to transfer the loading onto satisfactory ground.

## Section 3: Wall cladding

### General

- 3.1** Wall cladding presents a hazard if it becomes detached from the building. This section provides guidance on the support and fixing of wall cladding. An acceptable level of safety can be achieved by different means depending on the type and location of the cladding. The guidance given relates to all forms of cladding, including curtain walling and glass facades. It is not intended to provide guidance concerning the weather resistance of wall cladding which is included in Approved Document C, Site preparation and resistance to moisture, or guidance on resistance to spread of fire which is included in Approved Document B, Fire safety, or guidance in relation to sound insulation, which is included in Approved Document E, Resistance to the passage of sound.

### Technical approach

- 3.2** The cladding will meet the safety requirement if:
- (a) the cladding is capable of safely sustaining and transmitting to the supporting structure of the building all dead, imposed and wind loads, and
  - (b) the cladding is securely fixed to and supported by the structure of the building. This shall comprise both vertical support and horizontal restraint, and
  - (c) provision is made, where necessary, to accommodate differential movement of the cladding and the supporting structure of the building, and
  - (d) the cladding and its fixings (including any support components) are of durable materials; the design life of the fixings being not less than that of the cladding. Fixings shall be corrosion resistant and of a material type appropriate for the local environment.

### Loading

- 3.3** Wind loading on the cladding should be derived from BS 6399-2:1997 with due consideration given to local increases in wind suction arising from funnelling of the wind through gaps between buildings. Guidance on funnelling effects is given in BRE Digest 436 Wind loading on buildings – Brief guidance for using BS 6399-2:1997 available from BRE, Bucknalls Lane, Garston, Watford, Herts WD2 7JR.
- 3.4** Where the cladding is required to support other fixtures, e.g. handrails, and fittings, e.g. antennae and signboards, account should be taken of the loads and forces arising from such fixtures and fittings.
- 3.5** Where the wall cladding is required to function as pedestrian guarding to stairs, ramps, vertical drops of 600mm or greater or as a vehicle barrier, then account should be taken of the additional imposed loading, as stipulated in Approved Document K, Protection from falling, collision and impact.
- 3.6** Where the wall cladding is required to safely withstand lateral pressures from crowds, an appropriate design loading is given in BS 6399 Part 1 and the Guide to Safety at Sports Grounds (4th Edition, 1997).

## Fixings

**3.7** The selection of fixings for supporting cladding should be determined from a consideration of the proven performance of the fixing and the risks associated with the particular application. In this regard applications should be designated as being either non-redundant (where the failure of a single fixing could lead to the detachment of the cladding) or redundant (where failure or excessive movement of one fixing results in load sharing by adjacent fixings) and the required reliability of the fixing determined accordingly.

**Note:** Attention is drawn to the availability of anchors with an ETA (European Technical Approval) gained in accordance with the requirements of ETAG 001 Guideline for European Technical Approval Metal Anchors for use in Concrete Parts 1-5, which cover both redundant and non-redundant applications, and Part 6 which covers 'Anchors for multiple use in non-structural applications' and which can effectively be regarded as covering redundant use. The UK definition of 'multiple use' is contained in an annexe to the ETAG Part 6 and is framed in such a way that all applications can be validated as to whether or not they conform to this category without calculation. All ETAG parts may be downloaded in English from [www.eota.be](http://www.eota.be).

**3.8** The strength of fixings should be derived from tests using materials representative of the material into which the fixing is to be anchored, taking account of any inherent weaknesses that may affect the strength of the fixing, e.g. cracks in concrete due to shrinkage and flexure, or voids in masonry construction. The design loads will generally be available from the manufacturer's test data determined from a European Technical Approval (ETA) or an extant British Standard.

**Note:** ETAS are available which cover use either in both cracked and non-cracked concrete or in non-cracked concrete only. Those which cover both cracked and non-cracked concrete allow higher loads for use in non-cracked than in cracked concrete. Guidance on how to determine whether a particular concrete section may be regarded as cracked or non-cracked without reverting to stress calculations is contained in 'Use of anchors with European Technical Approvals. UK Guidance – Distinction between cracked and non-cracked concrete'. This is available on the BBA website [www.bbacerts.co.uk](http://www.bbacerts.co.uk) click tab 'ETA'.

## Further guidance

**3.9** The use of large panels of glass in cladding of walls and roofs where the cladding is not divided into small areas by load-bearing framing requires special consideration. Guidance is given in the following documents:

The Institution of Structural Engineers' Report on 'Structural use of glass in buildings' dated 1999, available from 11 Upper Belgrave Street, London SW1X 8BH.

'Nickel sulfide in toughened glass' published by the Centre for Window Cladding and Technology dated 2000.

**3.10** Further guidance on cladding is given in the following documents:

The Institution of Structural Engineers' Report on 'Aspects of Cladding' dated 1995.



The Institution of Structural Engineers' Report on 'Guide to the structural use of adhesives' dated 1999.

BS 8297:2000 Code of practice for the design and installation of non-load-bearing pre-cast concrete cladding.

BS 8298:1994 Code of practice for the design and installation of natural stone cladding and lining.

**3.11** Additional guidance on fixings is given in the following documents:

ETAG No. 001 1997 Guideline for European Technical Approvals of Metal Anchors for use in Concrete, European Organisation for Technical Approvals (EOTA), Brussels. All EOTA parts may be downloaded in English from [www.eota.be](http://www.eota.be).

English version published by the British Board of Agreement, PO Box 195, Bucknalls Lane, Garston, Watford, Hertfordshire WD25 9BA.

Part 1 Anchors in general.

Part 2 Torque controlled anchors.

Part 3 Undercut anchors.

Part 4 Deformation controlled anchors.

Part 5 Bonded anchors.

Part 6 Metal anchors for redundant use in concrete for lightweight systems.

BS 5080-1:1993 Structural fixings in concrete and masonry. Method of test for tensile loading.

CIRIA Report RP 566 Cladding Fixings: Good practice guidance, available from 6 Storey's Gate, London SW1P 3AU.

CIRIA Reports C579 and C589 Retention of masonry facades – Best practice guide.

Guidance notes published by the Construction Fixings Association, c/o Institute of Spring Technology, Henry Street, Sheffield, South Yorks S3 7EQ.

Guidance Note: Procedure for Site Testing Construction Fixings (1994).

Guidance Note: European Technical Approvals for Construction Fixings (1998).

Guidance Note: Anchor Selection (1995).

Guidance Note: Fixings and Fire (1998).

Guidance Note: Anchor Installation (1996).

Guidance Note: Bonded Anchors (1999).

Guidance Note: Heavy Duty Expansion Anchors (1997).

Guidance Note: Fixings for Brickwork and Blockwork (1997).

Guidance Note: Undercut Anchors (1998).

Guidance Note: Fixings and Corrosion (2002).

## Section 4: Roof covering

---

### Materials

- 4.1 All materials used to cover roofs, including transparent or translucent materials, but excluding windows of glass in residential buildings with roof pitches of not less than 15°, shall be capable of safely withstanding the concentrated imposed loads upon roofs specified in BS 6399: Part 3.

### Re-covering of roofs

- 4.2 The re-covering of roofs is commonly undertaken to extend the useful life of buildings. Roof structures may be required to carry underdrawing or insulation provided at a time later than their initial construction. This section provides guidance on determining whether such work to a roof constitutes a material alteration under the Building Regulations.
- 4.3 Where the work involves a significant change in the applied loading the structural integrity of the roof structure and the supporting structure should be checked to ensure that upon completion of the work the building is not less compliant with Requirement A1 than the original building.
- 4.4 A significant change in roof loading is when the loading upon the roof is increased by more than 15%.
- 4.5 Where such checking of the existing roof structure indicates that the construction is unable to sustain any proposed increase in loading (e.g. due to overstressed members or unacceptable deflection leading to ponding), appropriate strengthening work or replacement of roofing members should be undertaken. This is classified as a material alteration.
- 4.6 In carrying out the checks mentioned in paragraph 4.3 an increase of stress in a structural member arising from increased loading does not necessarily indicate that the roof structure is less compliant than the original roof provided an adequate factor of safety is maintained.
- 4.7 Where work will significantly decrease the roof dead loading, the roof structure and its anchorage to the supporting structure should be checked to ensure that an adequate factor of safety is maintained against uplift of the roof under imposed wind loading.

## Disproportionate collapse: The Requirement A3

---

This Approved Document deals with the following Requirements which are contained in the Building Regulations 2010.

| Requirement  | Limits on application |
|--|-----------------------|
| <b>Disproportionate collapse</b>   |                       |
| <b>A3.</b> The building shall be constructed so that in the event of an accident the building will not suffer collapse to an extent disproportionate to the cause. |                       |

# Guidance

---

## Performance

In the Secretary of State's view the Requirement of A3 will be met by an appropriate choice of measures to reduce the sensitivity of a building to disproportionate collapse should an accident occur.

## Introduction

0.1 The guidance in Section 5 deals with the means of meeting this performance criterion.

## Section 5: Reducing the sensitivity of the building to disproportionate collapse in the event of an accident

- 5.1 The requirement will be met by adopting the following approach for ensuring that the building is sufficiently robust to sustain a limited extent of damage or failure, depending on the class of the building, without collapse.
- (a) Determine the building class from Table 11.
  - (b) **For Class 1 buildings** – Provided the building has been designed and constructed in accordance with the rules given in this Approved Document, or other guidance referenced under Section 1, for meeting compliance with requirement A1 and A2 in normal use, no additional measures are likely to be necessary.
  - (c) **For Class 2A buildings** – Provide effective horizontal ties, or effective anchorage of suspended floors to walls, as described in the Codes and Standards listed under paragraph 5.2 for framed and load-bearing wall construction (the latter being defined in paragraph 5.3 below).

**Table 11** Building classes

| Classes  | Building type and occupancy  |
|--|--|
| 1  | Houses not exceeding 4 storeys<br>Agricultural buildings<br>Buildings into which people rarely go, provided no part of the building is closer to another building, or area where people do go, than a distance of 1.5 times the building height  |
| 2A   | 5 storey single occupancy houses<br>Hotels not exceeding 4 storeys<br>Flats, apartments and other residential buildings not exceeding 4 storeys<br>Offices not exceeding 4 storeys<br>Industrial buildings not exceeding 3 storeys<br>Retailing premises not exceeding 3 storeys of less than 2000m <sup>2</sup> floor area in each storey<br>Single-storey educational buildings<br>All buildings not exceeding 2 storeys to which members of the public are admitted and which contain floor areas not exceeding 2000m <sup>2</sup> at each storey                               |
| 2B   | Hotels, flats, apartments and other residential buildings greater than 4 storeys but not exceeding 15 storeys<br>Educational buildings greater than 1 storey but not exceeding 15 storeys<br>Retailing premises greater than 3 storeys but not exceeding 15 storeys<br>Hospitals not exceeding 3 storeys<br>Offices greater than 4 storeys but not exceeding 15 storeys<br>All buildings to which members of the public are admitted which contain floor areas exceeding 2000m <sup>2</sup> but less than 5000m <sup>2</sup> at each storey<br>Car parking not exceeding 6 storeys |
| 3  | All buildings defined above as Class 2A and 2B that exceed the limits on area and/or number of storeys<br>Grandstands accommodating more than 5000 spectators<br>Buildings containing hazardous substances and/or processes  |
| <b>Notes:</b>  |  |
| 1. For buildings intended for more than one type of use the Class should be that pertaining to the most onerous type.  |  |
| 2. In determining the number of storeys in a building, basement storeys may be excluded provided such basement storeys fulfil the robustness requirements of Class 2B buildings. |  |

- (d) **For Class 2B buildings** – Provide effective horizontal ties, as described in the Codes and Standards listed under paragraph 5.2 for framed and load-bearing wall construction (the latter being defined in paragraph 5.3 below), together with effective vertical ties, as defined in the Codes and Standards listed under paragraph 5.2, in all supporting columns and walls.

Alternatively, check that upon the notional removal of each supporting column and each beam supporting one or more columns, or any nominal length of load-bearing wall (one at a time in each storey of the building), the building remains stable and that the area of floor at any storey at risk of collapse does not exceed 15% of the floor area of that storey or 70m<sup>2</sup>, whichever is smaller, and does not extend further than the immediate adjacent storeys (see Diagram 24).

Where the notional removal of such columns and lengths of walls would result in an extent of damage in excess of the above limit, then such elements should be designed as a 'key element' as defined in paragraph 5.3 below.

- (e) **For Class 3 buildings** – A systematic risk assessment of the building should be undertaken taking into account all the normal hazards that may reasonably be foreseen, together with any abnormal hazards.

Critical situations for design should be selected that reflect the conditions that can reasonably be foreseen as possible during the life of the building. The structural form and concept and any protective measures should then be chosen and the detailed design of the structure and its elements undertaken in accordance with the recommendations given in the Codes and Standards given in paragraph 5.2.

- 5.2 Details of the effective horizontal and vertical ties, together with the design approaches for checking the integrity of the building following the notional removal of vertical members and the design of key elements, are available in the following Codes and Standards:

BS 5628-1:1992 Structural use of unreinforced masonry. Code of practice for use of masonry.

BS 5950-1:2000 Structural use of steelwork in building. Code of practice for design. Rolled and welded sections.

BS 8110-1:1997 Structural use of concrete. Code of practice for design and construction. BS 8110-2:1985 Structural use of concrete. Code of practice for special circumstances.

### 5.3 Definitions

#### Nominal length of load-bearing wall

The nominal length of load-bearing wall construction referred to in 5.1d should be taken as follows:

- in the case of a reinforced concrete wall, the distance between lateral supports subject to a maximum length not exceeding 2.25H.
- in the case of an external masonry wall, or timber or steel stud wall, the length measured between vertical lateral supports.
- in the case of an internal masonry wall, or timber or steel stud wall, a length not exceeding 2.25H.
- where H is the storey height in metres.

## Key elements

A 'key element', as referred to in paragraph 5.1d, should be capable of sustaining an accidental design loading of 34kN/m<sup>2</sup> applied in the horizontal and vertical directions (in one direction at a time) to the member and any attached components (e.g. cladding etc.) having regard to the ultimate strength of such components and their connections. Such accidental design loading should be assumed to act simultaneously with 1/3 of all normal characteristic loading (i.e. wind and imposed loading).

## Load-bearing construction

For the purposes of this Guidance the term 'load-bearing wall construction' includes masonry cross-wall construction and walls comprising close centred timber or lightweight steel section studs.

## Alternative approach

5.4 Alternatively, for any building which does not fall into the classes listed under Table 11 or for which the consequences of collapse may warrant particular examination of the risks involved, the performance may be met by the recommendations given in the following Reports:

'Guidance on Robustness and Provision against Accidental Actions' dated July,1999.

'Calibration of Proposed Revised Guidance on meeting Compliance with the Requirements of Building Regulation Part A3'. Revision of the Allott and Lomax proposals. Project Report No. 205966.

Both of the above documents are available on the following ODPM website [www.odpm.gov.uk](http://www.odpm.gov.uk)

Diagram 24 Area at risk of collapse in the event of an accident

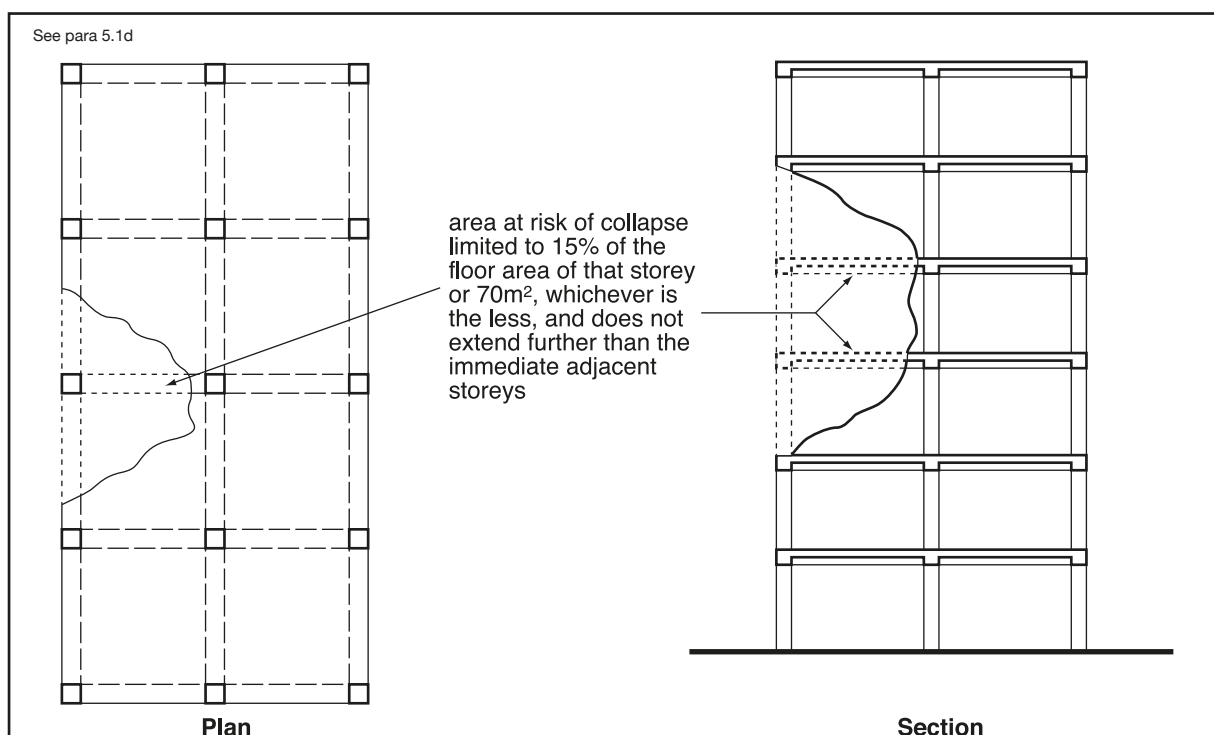

## Standards referred to

### A1/2

#### **BS 187:1978**

Specification for calcium silicate (sandlime and flintlime) bricks. AMD 5427 1987.

#### **BS 1243:1978**

Specification for metal ties for cavity wall construction. AMD 3651 1981, AMD 4024 1982. (Withdrawn and superseded by BS EN 845-1:2003 Specification for ancillary components for masonry. Ties, tension straps, hangers and brackets. AMD 14736 2003.)

#### **BS 5080-1:1993**

Structural fixings in concrete and masonry. Method of test for tensile loading. BS 5268-2:2002 Structural use of timber. Code of practice for permissible stress design, materials and workmanship.

#### **BS 5268-3:1998**

Structural use of timber. Code of practice for trussed rafter roofs.

#### **BS 5628-1:1992**

Code of practice for use of masonry. Structural use of unreinforced masonry. AMD 7745 1993, AMD 13680 2002. (Withdrawn and superseded by BS 5628-1:2005 Code of practice for the use of masonry. Structural use of reinforced masonry.)

#### **BS 5628-2:2000**

Code of practice for use of masonry. Structural use of reinforced and prestressed masonry. (Withdrawn and superseded by BS 5628-2:2005 Code of practice for the use of masonry. Structural use of reinforced and prestressed masonry.)

#### **BS 5628-3:2001**

Code of practice for use of masonry. Materials and components, design and workmanship. (Withdrawn and superseded by BS 5628-3:2005 Code of practice for the use of masonry. Materials and components, design and workmanship.)

#### **BS 5950-1:2000**

Structural use of steelwork in building. Code of practice for design. Rolled and welded sections. AMD 13199 2001.

#### **BS 5950-2:2001**

Structural use of steelwork in building. Specification for materials, fabrication and erection. Rolled and welded sections.

#### **BS 5950-3-1:1990**

Structural use of steelwork in building. Design in composite construction. Code of practice for design of simple and continuous composite beams.

#### **BS 5950-4:1994**

Structural use of steelwork in building. Code of practice for design of composite slabs with profiled steel sheeting. BS 5950-5:1998 Structural use of steelwork in building. Code of practice for design of cold formed thin gauge sections.

#### **BS 6399-1:1996**

Loading for buildings. Code of practice for dead and imposed loads. AMD 13669 2002.



**BS 6399-2:1997**

Loading for buildings. Code of practice for wind loads. AMD 13392 2002, AMD 14009 2002.

**BS 6399-3:1998**

Loading for buildings. Code of practice for imposed roof loads. AMD 6033 1988, AMD 9187 1996, AMD 9452 1997.

**BS 8002:1994**

Code of practice for earth retaining structures. AMD 8851 1995, AMD 12062 2001, AMD 13386 2001.

**BS 8004:1986**

Code of practice for foundations.

**BS 8103-1:1995**

Structural design of low-rise buildings. Code of practice for stability, site investigation, foundations and ground floor slabs for housing. AMD 8980 1995.

**BS 8103-2:1996**

Structural design of low-rise buildings. Code of practice for masonry walls for housing. (Superseded but remains current by BS 8103-2:2005 Structural design of low rise buildings. Code of practice for masonry walls for housing, but remains current.)

**BS 8103-3:1996**

Structural design of low-rise buildings. Code of practice for timber floors and roofs for housing.

**BS 8103-4:1995**

Structural design of low-rise buildings. Code of practice for suspended concrete floors for housing.

**BS 8110-1:1997**

Structural use of concrete. Code of practice for design and construction. AMD 9882 1998, AMD 13468 2002.

**BS 8110-2:1985**

Structural use of concrete. Code of practice for special circumstances. AMD 5914 1989, AMD 12061 2001.

**BS 8110-3:1995**

Structural use of concrete. Design charts for singly reinforced beams, doubly reinforced beams and rectangular columns. AMD 5918 1989.

**BS 8118-1:1991**

Structural use of aluminium. Code of practice for design. AMD 10485 1999.

**BS 8118-2:1991**

Structural use of aluminium. Specification for materials, workmanship and protection. AMD 10486 1999.

**BS 8297:2000**

Code of practice for design and installation of non-loadbearing precast concrete cladding. AMD 11064 2000, AMD 13018 2000.

**BS 8298:1994**

Code of practice for design and installation of natural stone cladding and lining.

**BS 8500-1:2002**

Concrete. Complementary British Standard to BS EN 206-1. Method of specifying and guidance for the specifier. AMD 14639 2003.

**BS 8500-2:2002**

Concrete. Complementary British Standard to BS EN 206-1. Specification for constituent materials and concrete. AMD 14640 2003.

**BS EN 197-1:2000**

Cement. Composition, specifications and conformity criteria for common elements. AMD 15209 2004.

**BS EN 197-2:2000**

Cement. Conformity evaluation.

**BS EN 771-1:2003**

Specification for masonry units. Clay masonry units. AMD 15998 2005.

**BS EN 771-2:2001**

Specification for masonry units. Calcium silicate masonry units. (Withdrawn and superseded by BS EN 771-2:2003 Specification for masonry units. Calcium silicate masonry units. AMD 15974 2005.)

**BS EN 771-3:2003**

Specification for masonry units. Aggregate concrete masonry units (dense and light-weight aggregates).

**BS EN 771-4:2001**

Specification for masonry units. Autoclaved aerated concrete masonry units. (Withdrawn and superseded by BS EN 771-4:2003 Specification for masonry units. Autoclaved aerated concrete masonry units. AMD 16000 2005.)

**BS EN 771-5:2003**

Specification for masonry units. Manufactured stone masonry units. AMD 15999 2005.

**BS EN 771-6:2001**

Specification for masonry units. Natural stone masonry units. (Withdrawn and superseded by BS EN 771-6:2005 Specification for masonry units. Natural stone masonry units.)

**BS EN 845-1:2001**

Specification for ancillary components for masonry. Ties, tension straps, hangers and brackets. (Withdrawn and superseded by BS EN 845-1:2003 Specification for ancillary components for masonry. Ties, tension straps, hangers and brackets. AMD 14736 2003.)

**BS EN 845-2:2001**

Specification for ancillary components for masonry. Lintels. (Withdrawn and superseded by BS EN 845-2:2003 Specification for ancillary components for masonry. Lintels.)

**BS EN 845-3:2001**

Specification for ancillary components for masonry. Bed joint reinforcement of steel meshwork. (Withdrawn and superseded by BS EN 845-3:2003 Specification for ancillary components for masonry. Bed joint reinforcement of steel meshwork.)

**BS EN 998-2:2002**

Specification for mortar for masonry. Masonry mortar. (Withdrawn and superseded by BS EN 998-2:2003 Specification for mortar for masonry. Masonry mortar.)

**BS EN 12620:2002**

Aggregates for concrete. AMD 15333 2004.

**DD 140-1:1986**

Wall ties. Method of test for mortar joint and timber frame connections. (Withdrawn and superseded by BS 845-1:2003 Specification for ancillary components for masonry. Ties, tension straps, hangers and brackets. AMD 14736 2003.)

**DD 140-2:1987**

Wall ties. Recommendations for design of wall ties. AMD 7971 1994.

**A3**

**BS 5628-1:1992**

Code of practice for use of masonry. Structural use of unreinforced masonry. AMD 7745 1993, AMD 13680 2002.

(Partially superseded by BS EN 1052-1:1999 Method of test for masonry. Determination of compressive strength. Withdrawn and superseded by BS 5628-1:2005 Code of practice for the use of masonry. Structural use of reinforced masonry.)

**BS 5950-1:2000**

Structural use of steelwork in building. Code of practice for design. Rolled and welded sections. AMD 13199 2001.

**BS 8110-1:1997**

Structural use of concrete. Code of practice for design and construction. AMD 9882 1998, AMD 13468 2002.

**BS 8110-2:1985**

Structural use of concrete. Code of practice for special circumstances. AMD 5914 1989, AMD 12061 2001. A\_text.indd 45 02/03/2012 10:09